

4
7-30-82
(S)

I-5644

①

DR 865

GEND
010
VOL. III

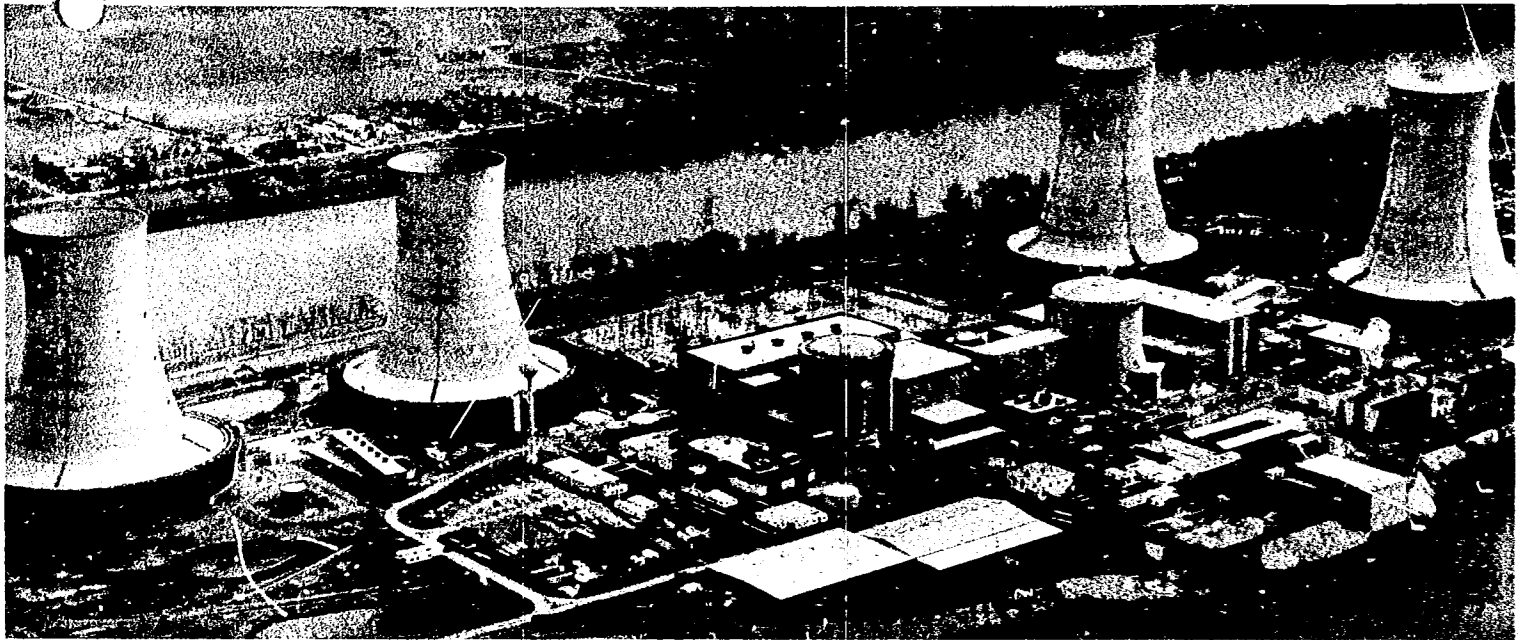

GEND

General Public Utilities • Electric Power Research Institute • U.S. Nuclear Regulatory Commission • U.S. Department of Energy

**In-Vessel Inspection Before Head Removal:
TMI II
Phase I
(Tooling and System Design
and Verification)**

MASTER

G. S. Carter
R. F. Ryan
A. W. Pieleck
H. Q. Bibb

September 1982

Prepared for the
U.S. Department of Energy
Three Mile Island Operations Office
Under DOE Contract No. DE-AC07-76ID01570

DISTRIBUTION OF THIS DOCUMENT IS UNLIMITED

Printed in the United States of America

Available from
National Technical Information Service
U.S. Department of Commerce
5285 Port Royal Road
Springfield, VA 22161
NTIS Price Codes: Printed Copy A07
Microfiche A01

DISCLAIMER

This book was prepared as an account of work sponsored by an agency of the United States Government. Neither the United States Government nor any agency thereof, nor any of their employees, makes any warranty, express or implied, or assumes any legal liability or responsibility for the accuracy, completeness, or usefulness of any information, apparatus, product or process disclosed, or represents that its use would not infringe privately owned rights. References herein to any specific commercial product, process, or service by trade name, trademark, manufacturer, or otherwise, does not necessarily constitute or imply its endorsement, recommendation, or favoring by the United States Government or any agency thereof. The views and opinions of authors expressed herein do not necessarily state or reflect those of the United States Government or any agency thereof.

GEND--010 Vol. 3

DE92 022519

GEND-010, Vol. III
Distribution Category: UC-78
TMI Supplement

**IN-VESSEL INSPECTION BEFORE HEAD REMOVAL:
TMI II,
PHASE III
(TOOLING AND SYSTEMS DESIGN
AND VERIFICATION)**

**G. S. Carter
R. F. Ryan
A. W. Pieleck
H. Q. Bibb**

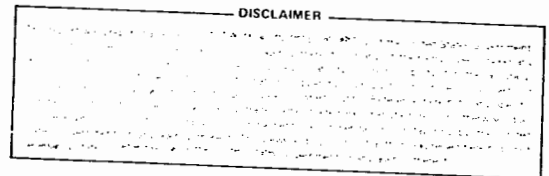

Published September 1982

**Prepared by Babcock & Wilcox
for GPU Service Corporation
Under Subcontract No. 595-7100**

**Prepared for EG&G Idaho, Inc.
Under Subcontract No. K-5003
and the U.S. Department of Energy
Three Mile Island Operations Office
Under DOE Contract No. DE-AC07-76IDO1570**

DISTRIBUTION OF THIS DOCUMENT IS UNLIMITED

SUMMARY

The need for an internal inspection of the Three Mile Island Unit 2 (TMI-2) reactor vessel (RV) and fuel before RV head removal was identified in the TMI-2 Examination Planning Group report. The intent of this inspection is to

1. Provide information, at the earliest possible date, on the operational conditions to be encountered in the reactor. Currently, planning of these evolutions must cover a broad spectrum of potential conditions, and this spectrum can only be reduced by actual observation.
2. Provide information to help "benchmark" the range of damage estimates now in use. The damage estimates, in turn, provide input for 1 above. At this stage, the benchmark would consist of a damage assessment (e.g., peak temperatures and effects) of the upper core internals, the extent of fuel assembly "slumping," and the distribution/type/size of core debris in the upper vessel region.
3. Provide the technical community with information on the in-vessel conditions at the earliest possible date.

The following paragraphs summarize the approach used in planning the equipment development program.

The initial penetration into the TMI-2 reactor vessel will be made through a vent valve thermocouple nozzle. Five of these nozzles will be opened, four for use by a reactor vessel purge system and one for the reactor vessel primary water level indicator. The purge system will provide a continuous inflow of air through all subsequent penetrations open to the containment.

Up to three control rod drive mechanisms (CRDMs) will initially be removed by normal or abnormal procedures to permit the insertion of a video camera and lighting and sampling equipment. The locations for removal are along the outer periphery of the control rod drive matrix.

BAW-1725

April 1982

IN-VESSEL INSPECTION BEFORE HEAD REMOVAL

— TMI-2 PHASE III —

Tooling and Systems Design and Verification

April 1982

IN-VESSEL INSPECTION BEFORE HEAD REMOVAL

— TMI-2 PHASE III —

Tooling and Systems Design and Verification

B&W Contract No. 595-3174

B&W Task No. 51-01

EG&G Task Order No. 8

by

G. S. Carter, R. F. Ryan,

A. W. Pieleck, H. Q. Bibb

Reviewed by:



Approved by:



Prepared for

GPU Nuclear Corporation
260 Cherry Hill Road
Parsippany, New Jersey 07054

by

BABCOCK & WILCOX
Nuclear Power Group
Nuclear Power Generation Division
P. O. Box 1260
Lynchburg, Virginia 24505

Babcock & Wilcox

Once placed inside the head through the CRDM nozzle, the video camera will inspect the plenum cover. A special manipulator will be used to move the camera over to the edge of the plenum cover. At suitable locations the camera will be lowered to permit video inspections inside the plenum cylinder. While the camera is inside the plenum cylinder it will be lowered to inspect the tops of several peripheral fuel assemblies. The camera will also be lowered down the center of the guide tube brazement to inspect the brazement and a portion of the top of one fuel assembly.

An attempt will be made to uncouple the leadscrew and remove the center CRDM once the peripheral inspection is complete. An inspection will be performed by lowering the camera and light down the guide tube brazement. One CRDM nozzle is needed for this inspection and any CRDM close to the center that can be uncoupled to allow CRDM removal can be used.

The development of cameras, manipulators, and special tooling to remove CRDM leadscrews (in case normal uncoupling can not be accomplished) has been completed and satisfactorily demonstrated on various mockups during phase III of this task. Draft procedures for the use of these tools and equipment have been prepared. These procedures will have to be modified to consider ALARA due to the high radiation levels being observed in the vicinity of the reactor closure head. The effects of head decontamination will be considered in the procedures. This work, in conjunction with the performance of the actual inspection at TMI-2, is included in the next task.

The following tooling and/or systems have been developed:

1. The purge system consists of two centrifugal compressor pumps, a control valve, and various lengths of flexible tubing. The tubing is connected to the four thermocouple nozzles and manifolded into parallel redundant pumps with proper valving. The pump, when activated, will direct air flow down the open control rod drive nozzles into the area above the plenum and then out the thermocouple nozzles to the suction side of the pump. The air discharged from the plenum area passes to the waste header (see Figure 3-3).
2. The water level monitoring system, commonly referred to as a "bubbler" system, is mounted into one of the open thermocouple nozzles. The controls and gages for the system are mounted on a panel located on the

railing of the control rod drive structure operating platform. The indicators on the panel may be monitored by the operating personnel conducting the inspection to provide them with information on vessel water level. This information is important for performing the inspection and shielding personnel.

3. The CRDM bolt removal tool was developed as a contingency tool for untorquing the holddown bolts that secure the CRDM motor tube to the reactor vessel flange. This tool is designed to produce a higher torque than the normal bolt removal tool in the event these bolts are stuck. The tool consists of a hex-head cup connected to a long shank that terminates at the top CRDM operating platform. Torque multipliers attached to the upper end of the long shank provide the torque to shear the bolts should this become necessary; 2500 ft-lb of torque may be applied.
4. The stator removal tool was developed to remove the stator from the CRDM housing to provide access to the CRDM holddown bolts. The tool consists of a yoke positioned under the stator from the CRDM platform. The yoke is connected by four cables and a spreader plate to a crane that is used to lift the stator.
5. A plasma arc cutting system is provided for contingency cutting of leadscrews. If normal uncoupling of the leadscrew is not possible, the plasma arc will be used to cut the leadscrew above the reactor vessel flange. This in turn will allow removal of the CRDM motor housing and the upper end of the leadscrew.
6. The push pull leadscrew separator is provided to shear the leadscrew pins near the top of the control rod spider. This clears a path to the top of a fuel assembly for viewing. The tool fits around the leadscrew and inside the control rod guide brazement. The segmented nut on its upper end engages the threads of the leadscrew immediately below the plasma arc cutting site. The segmented nut is connected to a hydraulic jack that applies an upward force to the nut while pushing downward on the control rod spider. The force applied is sufficient to shear the leadscrew pin. This is a contingency tool to uncouple a leadscrew from the control rod spider should normal uncoupling methods be unsuccessful.

7. Video cameras, lights, and camera manipulators make up a complete underwater video system specifically designed for nuclear reactor inspections. The camera consists of a camera head, which is inserted into the reactor, and a control unit mounted at the top of the service structure connected by 100 feet of integral cable. The camera is inserted into the camera manipulator (a long tube with a movable extension on its lower end). By proper articulation of the manipulator end, the camera may be located and then lowered into the reactor vessel to view various places in the vessel above the active fuel line. Continuous TV monitoring of the camera output is provided at the camera control unit.
8. Manipulator support tubes are provided to extend the CRDM nozzle enclosure to the top of the service structure. These are 3.5-inch-diameter aluminum tubes secured to the CRDM closure flange. The upper end of the tube is at the service structure for access to the reactor vessel.
9. The swipe tool has been provided to extract samples of the debris expected to be found on top of the plenum cover. The tool consists of a long, square aluminum tube containing the swipe sample holder. The tube has three hinged sections at its end which are controlled by wires. The swipe sample is articulated to the plenum cover and retrieved by means of a stiff wire inside the tool.
10. The in-head plasma arc cutter manipulator, clamp manipulator, and clamp are provided to clamp the leadscrew inside the RV head and then cut the leadscrew above the clamp. The plasma arc cutting system described in item 5 will be used for in-head cutting. This system will permit separating leadscrews that cannot be uncoupled.

FOREWORD

The DOE/EPRI/NRC/GPU Joint Technical Working Group*, formulated various programs for obtaining technical information from the recovery of TMI-2. This information is of interest to and will be made available to the nuclear community. One of the many tasks outlined by this group was entitled, "Recommendations on In-Place TMI-2 Core Damage Examinations," published in April 1980. The first recommendation, "Inspection of Reactor Internals and Fuel Prior to RV Head Removal," included the following paragraph which describes the need for the work:

It is important that as much information as practical be obtained on the conditions inside the reactor prior to reactor disassembly. This information will serve to benchmark the various analyses already completed or underway. It will also guide the development of programs to obtain more data on the TMI-2 core and other experiments planned or underway. The early look into the reactor vessel will also provide data for detailed planning of the examination programs to be conducted during and after defueling.

Because of the close interface with the reactor, GPU assigned B&W the task of developing hardware to perform this work in June 1980. The work related to developing the equipment has been completed.

The task was divided into three phases:

1. Conceptual development.
2. Tooling and system design.
3. Detailed tooling design, fabrication, and mockup testing of all tools and equipment.

- - - - -
*Department of Energy, Electric Power Research Institute, Nuclear Regulatory Commission, and GPU Nuclear Corporation.

A separate task is intended that will include preparing the actual detailed procedures, training personnel, and performing the inspection in the TMI-2 reactor vessel.

The program was funded by the DOE through the EG&G Technical Integration Office.* Before beginning the work, EG&G prepared a detailed work scope. As work progressed, this work scope was amended as required to incorporate changes to the original. The work scope and change order are given in Appendix A. Various other minor changes to this scope have been mutually accepted. This report describes the tools and equipment developed for the examination. It includes preliminary procedures for tools used in the TMI-2 reactor vessel and provides information needed to prepare the Technical Evaluation Report, which will be submitted to the NRC for approval to perform the examination.

*EG&G: EG&G Idaho.

Babcock & Wilcox
Nuclear Power Group
Lynchburg, Virginia

Report BAW-1725

April 1972

In-Vessel Inspection Before Head Removal -- TMI-2 Phase III --
Tooling and Systems Design and Verification

Key Words: Leadscrew, Camera, Video, Inspection, Core

ABSTRACT

Under EG&G Contract K-9003 to General Public Utilities Corporation, a Task Order was assigned to Babcock & Wilcox to develop and provide equipment to facilitate early assessment of core damage in the Three Mile Island Unit 2 reactor vessel head. Described herein is the work performed, the equipment developed, and the tests conducted with this equipment on various mockups used to simulate the constraints inside and outside the reactor vessel that affect the performance of the inspection. The tooling developed provides several methods of removing a few control rod drive leadscrews from the reactor, thereby providing paths into which cameras and lights may be inserted to permit video viewing of many potentially damaged areas in the reactor vessel. The tools, equipment, and cameras demonstrated that these tasks could be accomplished. Further work will be required to integrate these inspections into the total reactor disassembly program by developing detailed procedures considering plant conditions, radiation levels, and contamination levels of equipment removed from the reactor.

CONTENTS

	Page
1. INTRODUCTION	1-1
2. GENERAL APPROACH	2-1
3. PROJECT DESCRIPTION	3-1
3.1. Penetration Selection	3-1
3.2. Secondary Boundary Concepts and Radiation Levels	3-3
3.3. Contingency Tooling	3-13
3.4. Other Access Methods	3-22
3.5. Inspection Technique	3-25
3.6. Manipulators	3-30
3.7. Radiological Boundary Equipment	3-31
3.8. Mockups	3-36
3.9. Radioactive Equipment Storage	3-36
3.9.1. Reactor Component Storage	3-39
3.9.2. Tool and Equipment Storage	3-39
3.10. Interface Requirements	3-39
4. EQUIPMENT — PURPOSE AND DESCRIPTION	4-1
4.1. Support Equipment	4-1
4.1.1. Purge System	4-1
4.1.2. Manipulator Support Tubes	4-2
4.1.3. Closures	4-11
4.1.4. Water Level Sensing Equipment	4-15
4.2. Control Rod Drive Mechanism Removal Tools	4-18
4.2.1. Bolt Removal Tool	4-18
4.2.2. Stator Removal Tool	4-24
4.2.3. Ex-Head Plasma-Arc Cutting	4-27
4.2.4. In-Head Plasma-Arc Cutting and Leadscrew Clamping	4-34
4.3. Video Equipment	4-41
4.3.1. Television Equipment	4-41
4.3.2. In-Head and Underwater Lights	4-42
4.3.4. Murky Water Viewing Equipment	4-45
4.3.5. Camera Manipulators	4-48
4.4. Swipe Tool	4-49
5. MOCKUP DESCRIPTIONS AND TEST RESULTS	5-1
5.1. Diamond Power Specialty Mockup	5-2
5.2. Ex-Head Mockup for Plasma-Arc Mockup Design and Construction	5-9

CONTENTS (Cont'd)

	Page
5.3. In-Head Mockup -- Plasma-Arc Mockup	
Design and Construction	5-16
5.4. Push-Pull Tool Mockup	5-21
5.4.1. Mockup Design and Construction	5-21
5.4.2. Mockup Testing	5-23
5.5. Bolt Removal Tool Testing	5-23
5.6. Purge System Mockup	5-24
5.7. Water Level Sensing System Mockup	5-26
5.8. Manipulator Support Tubes	5-26
5.9. Underwater Lights	5-28
5.10. Stator Removal Tool	5-28
5.11. Camera and Light Manipulators	5-28
5.12. Mockup Testing of Murky Water Viewing Attachment	5-29
5.13. Blind Flange Tool	5-29
5.14. Missile Shield Discussion	5-29
5.15. Rigging Information	5-29
5.16. Tool Access Through Air-Lock	5-30
6. FUTURE WORK	6-1
6.1. ALARA Concerns	6-1
6.2. Implementation Phase	6-2
6.3. Plant Conditions	6-2
6.4. Staifing and Training	6-3
 APPENDIXES	
A. Scope of Work for TMI-2 Reactor Vessel	
Inspection Before Head Removal	A-1
B. Time Studies	B-1
C. EG&G Task Order No. 8 Tools Operating Procedures	C-1

List of Tables

Table	
2-1. Inspection Locations	2-4
3-1. Camera Specification Table	3-27

List of Figures

Figure	Page
1-1. Participant Relationship of Task Order	1-3
2-1. Location of Control Assemblies	2-3
2-2. Reactor and Service Structure	2-5
2-3. Inspection Locations	2-6
3-1. Thermocouple Nozzle Assembly	3-4
3-2. General Approach	3-5
3-3. Purge System	3-6
3-4. Reactor Vessel Service Structure Control Rod Drive Mechanism	3-8
3-5. Reactor Vessel Service Structure Inside of Barrel	3-9
3-6. Reactor Head Radiation Survey Looking North	3-10
3-7. Fuel Pool Radiation Survey	3-11
3-8. Reactor Head Radiator Survey Looking South	3-12
3-9. Contingency Procedure for First CRDM Removal	3-14
3-10. Contingency Procedure for Adjacent CRDM Removal	3-15
3-11. CRDM Access Hole in Service Structure	3-17
3-12. Control Rod Drive Mechanism	3-18
3-13. Leadscrew Assembly	3-20
3-14. Relative Strengths	3-21
3-15. Forces Necessary to Separate Leadscrew	3-21
3-16. Leadscrew Puller/Separator	3-23
3-17. In-Head Leadscrew Cutter	3-24
3-18. Concept for Murky Water Viewing	3-29
3-19. Option Using CRDM Tube From SSS	3-32
3-20. Hinged Tube Manipulator for Auxiliary Lights	3-33
3-21. Manipulator for Swipe Sampling	3-34
3-22. Swipe Sampler	3-35
3-23. Test Facility Mockup	3-37
3-24. Motor Tube/Leadscrew Cutting Mockup	3-38
4-1. Purge System	4-3
4-2. Manifold and Breaker Valve Assembly	4-4
4-3. Ring Compressor	4-5
4-4. Controller and Differential Pressure Cell	4-6
4-5. Flexible Hoses	4-7
4-6. Manipulator Support Tubes	4-8
4-7. Manipulator Support Tube	4-9
4-8. Nut Rings	4-10
4-9. Manipulator Support Tube Coupling	4-12
4-10. Closures	4-13
4-11. CRDM and Thermocouple Nozzle Blind Flanges	4-14
4-12. Water Level Sensing System	4-16
4-13. Water Level "Bubble Pipe" Indication System	4-17
4-14. Bolt Removal Tool and Tool Plate	4-19
4-15. Bolt Removal Tool Accessories	4-20
4-16a. Torque Multipliers and Tool Plate	4-21
4-16b. Tool Plate and Torque Multipliers During Mockup Testing	4-21
4-17. Lower End of Bolt Removal Tool	4-22
4-18. Stator Removal Tool	4-25
4-19. Mockup Operation of Stator Removal Tool	4-26
4-20. Leadscrew Support Tube Clamp	4-29

Figures (Cont'd)

Figure	Page
4-21. Leadscrew Clamp	4-30
4-22. Leadscrew Centering Lifting Tool	4-31
4-23. Push-Pull Tool and Accessories	4-32
4-24. Manipulator Support Tube	4-35
4-25. Reactor and Service Structure	4-36
4-26. Underhead Plasma Cutter and Clamp	4-38
4-27. In-Head Leadscrew Cutting Tools	4-39
4-28. In-Head Leadscrew Cutting Tools	4-40
4-29. Camera Control Unit	4-43
4-30. TV Camera Head	4-44
4-31. Underhead Special Lighting	4-46
4-32. Camera With Shield	4-47
4-33. Underhead Camera Manipulator	4-50
4-34. Plenum Cover Sample Tool	4-51
5-1. Diamond Power Mockup Facilities	5-4
5-2. Diamond Power Mockup Facilities	5-5
5-3. Diamond Power Mockup Facilities	5-6
5-4. Diamond Power Mockup Facilities	5-7
5-5. Diamond Power Mockup Facilities	5-8
5-6. Location of Platform for Ex-Head Cutting	5-10
5-7. Mockup of Physical Constraints at RV Head	5-11
5-8. Mockup of Ex-Head Leadscrew Plasma-Arc Cutting	5-13
5-9. Mockup of Ex-Head Leadscrew Plasma-Arc Cutting	5-14
5-10. Mockup In-Head Cutting	5-17
5-11. Push-Pull at LRC	5-22
5-12. Purge System Mockup at B&W Special Products	5-25
5-13. Water Level Mockup at B&W Special Products	5-27

1. INTRODUCTION

The overall objective of this program is to provide the capability to inspect the upper reactor vessel (RV) internals and upper fuel assembly end fittings in TMI-2 before RV head removal. If core damage is excessive, inspection of the upper ends of damaged fuel may also be possible. The information to be obtained would

1. Determine the actual damage to the upper core internals and fuel more accurately and provide some quantitative estimate of fuel debris in the upper vessel region.
2. Provide more accurate information than is presently available from the analysis as to the actual conditions in the reactor vessel. These observations would influence the design of tools and equipment needed to disassemble and defuel the reactor.
3. Provide the technical community with information on the damage in the RV at an early date.

In May 1980, B&W described to GPU a program for developing equipment and procedures for penetrating the TMI-2 RV to assess core damage. This program included the work to develop, design, and fabricate the appropriate hardware; to perform prototype demonstrations; and to carry out the in-vessel inspection. Again in May, EG&G and B&W personnel met in Lynchburg, Virginia, to develop plans for early core damage assessment. These plans were to include the following:

1. Types of inspection devices that might be inserted into the reactor vessel.
2. Information that could be obtained with these instruments.
3. The location and nature of relevant information that could be obtained from a vessel examination.

Preliminary work scopes defining those results that were considered valuable were then generated. In parallel with this effort, Task Order 8 was initiated

by EG&G with GPU on May 22, 1980, to have B&W work on Phase I, "Conceptual Design of Equipment Required to Perform the Through-Head Inspection of TMI-2."

In early August 1980, the draft Phase I report was transmitted for review by EG&G, GPU, BNC, BNI, and DOE.* In addition to the through head inspection, report included recommendations for in-vessel debris sampling, radiation measurements, and water level monitoring. A meeting was held at B&W on August 7, 1980 (DOE, EG&G, GPU, BNC, and BNI) to review the draft Phase I report. This group recommended that debris sampling and water level monitoring be included in Phases II and III. A modification to the task covering these and additional recommendations was then initiated.

The draft Phase II report was released for review in November 1980. A review meeting was organized by EG&G and held at TMI on December 11, 1980; GPU, EG&G, DOE, BNI, and BNC were represented. Written Phase II review comments were provided to B&W. The review comments were considered, and subsequent potential changes to the task order were discussed. B&W was directed to proceed with Phase III. GPU designated their contractor (BNC) to assume responsibility for technical administration of the balance of the task. Phase III proceeded with technical interface with BNC from February 1, 1981, to completion.

Figure 1-1 shows the relationships of the various organizations involved in the task.

- - - - -
* BNC: Bechtel Northern Corporation, BNI: Bechtel National Incorporated.

Figure 1-1. Participant Relationship of Task Order

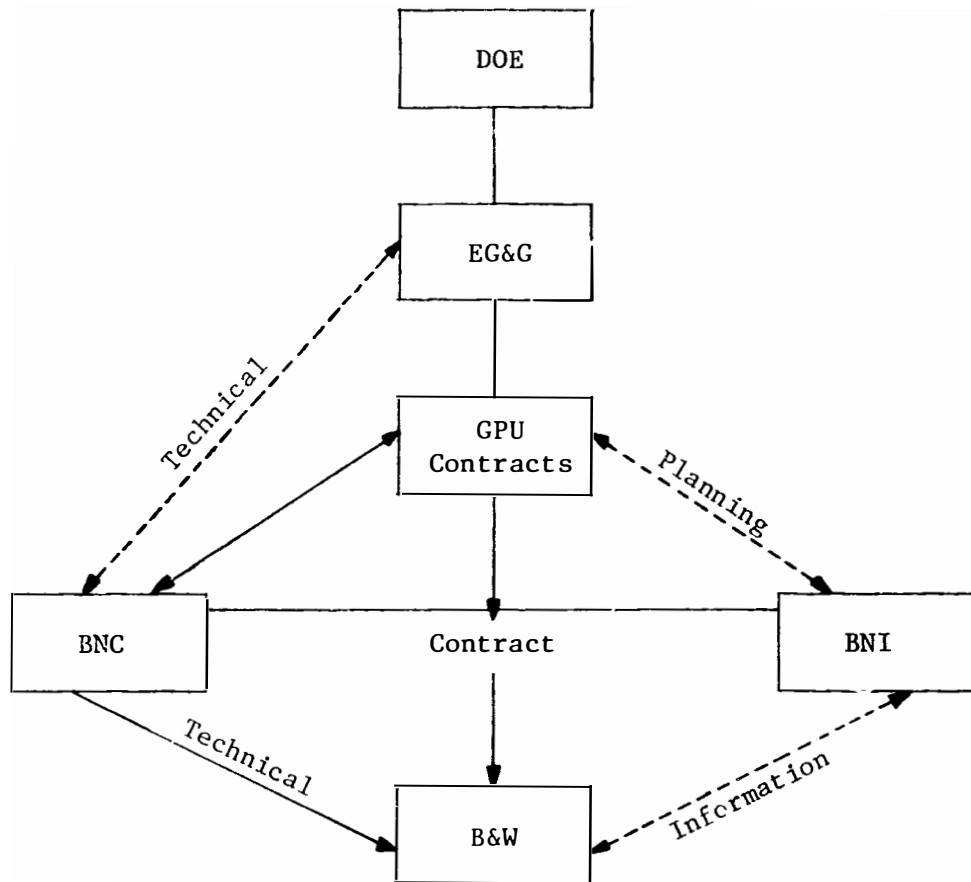

2. GENERAL APPROACH

The objective of the in-vessel inspection before head removal is to provide an internal inspection of the RV and fuel assemblies before head removal. Since the degree of damage in the TMI-2 reactor is not known, it is important that information be obtained from inside the reactor. This information will guide the development of the programs to obtain more information on the TMI-2 core damage and assist in the development of tools and equipment to defuel the reactor.

Before performing the inspection, the missile shields above the control rod drive service structure should be removed. Tools have been designed to operate under the missile shield, but its removal will greatly facilitate the inspection program. Consequently, the base inspection plan includes shield removal with the "to be refurbished" building crane. The concrete shield blocks may be placed on top of the D-ring, the usual storage place for these large concrete missile shields.

Before working with the reactor coolant system (RCS), acceptable heat removal should be demonstrated by the present radiant cooling to the building atmosphere. Radiation control safety studies should be completed before performing any work, and a mockup should be available to train personnel, in tool check-out procedures verification.

Head service lines should be disconnected before the starting uncoupling operations. The CRDMs should be vented. By leaving the system full and at a slight positive pressure (less than 50 psig), the CRDMs can be vented to the plant gaseous waste disposal system or the reactor building ventilation system.

To disconnect the CRDMs, the RCS must be brought to atmospheric pressure and the water level must be lowered to a level below the CRDM vents. The CRDMs can then be vented to remove any accumulated gas.

Lowering the RCS water level will require that storage facilities outside the reactor building (RB) to accommodate approximately 35,000 to 40,000 gallons of

water. Present plans recommend cleanup of the RCS water before performing operations relating to CRDM uncoupling and venting. However, if plans are made to lower the water in the RCS prior to coolant treatment, then the radiation levels may be higher than with the treated water.

When the RCS water is lowered to about 1 foot above the plenum cover, the connections for the gas purge system may be made. The gas purge system is designed to provide an inflow of air down the CRDM motor housing, into the RV head spaces, and out through a manifold connected to four thermocouple nozzles on the RV head. This inflow of air will prevent radioactive gases in the vessel from escaping to the area on the service structure where the technicians may be located. Another thermocouple nozzle will be used to install the water level indication system.

Access to the RV for inspection will initially be through three control rod drive nozzles from which the drive mechanisms have been removed. Normal uncoupling will be attempted before using any of the many contingency CRDM removal tools provided. If normal uncoupling is successful, these tools may not be needed. The locations recommended for CRDM removal for this inspection are shown in Figure 2-1.

If normal CRDM uncoupling cannot be achieved, the ex-head plasma arc cutting system may be used to cut a leadscrew immediately above the CRDM reactor vessel nozzle. With appropriate tools, the CRDM housing may be raised a few inches above the vessel flange, and the plasma arc torch can be used to cut a CRDM leadscrew. The CRDM housing and upper leadscrew can then be removed. The push/pull tool may be engaged with the lower leadscrew section and hydraulic pressure applied to shear the pins at the lower end of the leadscrew extension. The leadscrew may thus be removed through the CRDM motor housing. This will provide for camera access down the CRD guide tube in the plenum assembly to the top of the fuel assembly.

Once placed inside the head through the manipulator guide tube and the CRDM nozzle, the video camera will permit inspection of the plenum cover. A special manipulator will be used to move the camera over the edge of the plenum cover. At suitable locations, the camera can be lowered to view both the inside and outside of the plenum cylinder. This will permit video inspections of the plenum cylinder and core support shield. While the camera is inside the plenum

Figure 2-1. Location of Control Assemblies

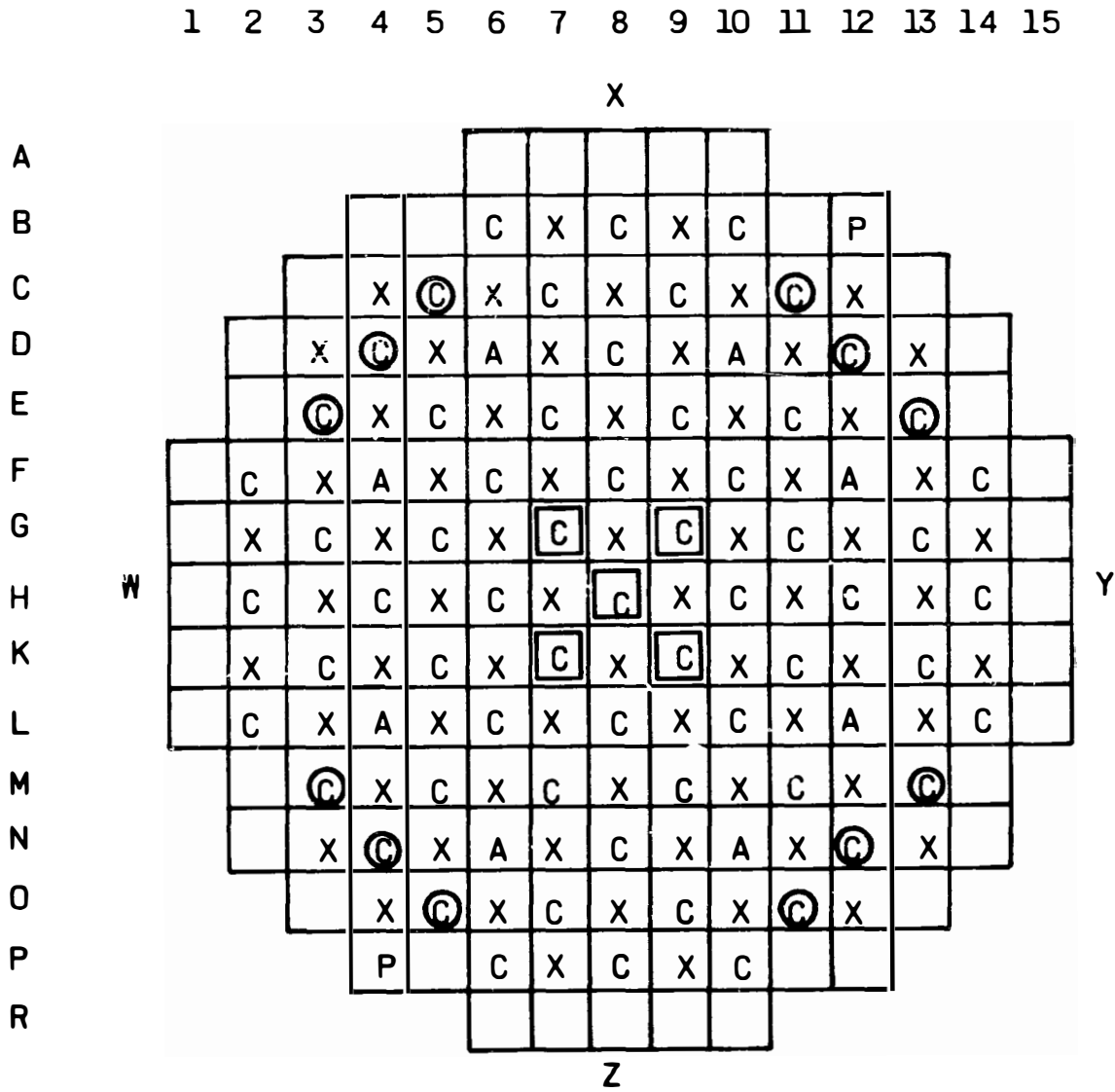

- CONTAINS NO CONTROL COMPONENT
- ⊠ CONTROL ROD ASSEMBLIES
- ⊡ AXIAL POWER SHAPING ROD ASSEMBLIES
- ⊢ BURNABLE POISON ROD ASSEMBLIES
- ⊣ PRIMARY NEUTRON SOURCES
- ⊙ DESIRABLE LOCATIONS FOR INITIAL CRDM REMOVAL
- ⊠ DESIRABLE LOCATIONS FOR CENTER CRDM REMOVAL

cylinder it will be lowered to inspect the top of several peripheral fuel assemblies. The camera may also be lowered down the center of a guide tube brazement to inspect the brazement and a portion of the top of the fuel assembly. Contingent on normal CRDM uncoupling, a center CRDM housing may also be removed and the camera lowered to inspect a center fuel assembly. Inspection locations are described further in Table 2-1 and shown in Figures 2-2 and 2-3.

Table 2-1. Inspection Locations

<u>Inspection area</u>	<u>Access route^(a)</u>	<u>Information anticipated</u>
1. Plenum cover	Any open CRDM typical of several locations; view is straight down or at an angle.	Presence, size, and distribution of debris, if present. Presence of debris may be indicative of flow paths and velocities (size and distribution) following core damage. The debris may be a potential radiation-field problem for head removal.
2. Internal structure of control rod guide tubes	Access 1 and 4 typical of several locations. Camera is dropped straight down. Right angle attachment is used	Distortion of tube and/or control rod guide brazements; indicative of thermal distortion of plenum and/or temperature >2300F (braze melting point). May indicate general condition of the plenum.
3. Fuel assembly upper structures	Access 1, 3, and 4. Typical of several locations. Route 4 provides access to peripheral fuel assemblies which do not contain control elements.	Evidence of core "slumping," missing upper structure(s), and/or accumulations of debris above the upper structures. Inference of core damage severity.
4. Core region (below upper grid)	Access 1, 3, and 4. Available <u>only if</u> fuel assembly upper structure is found to be missing (i.e. has dropped into core).	Camera lowered into core; the only direct access route.

(a) See Figure 2-3.

Figure 2-2. Reactor and Service Structure

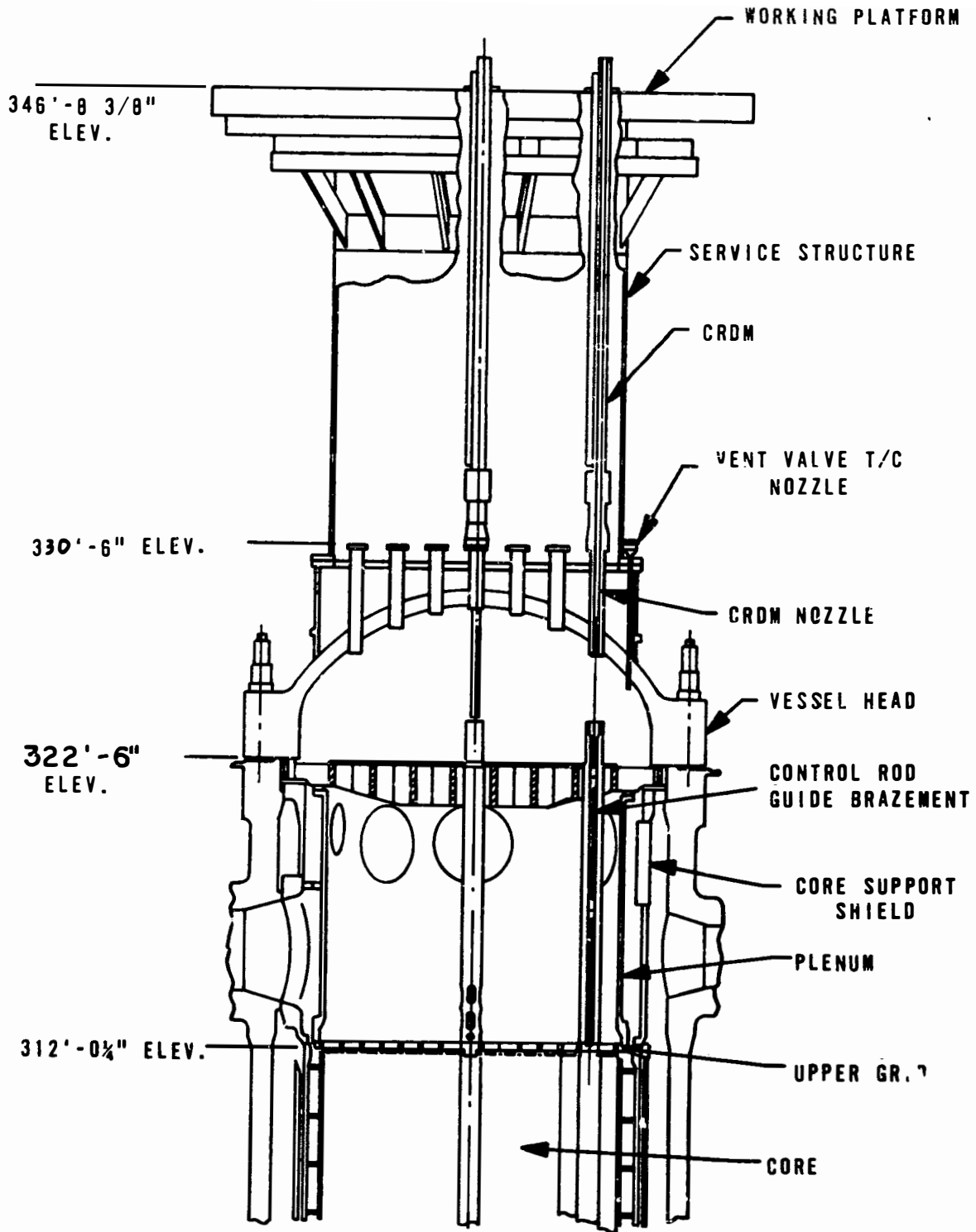
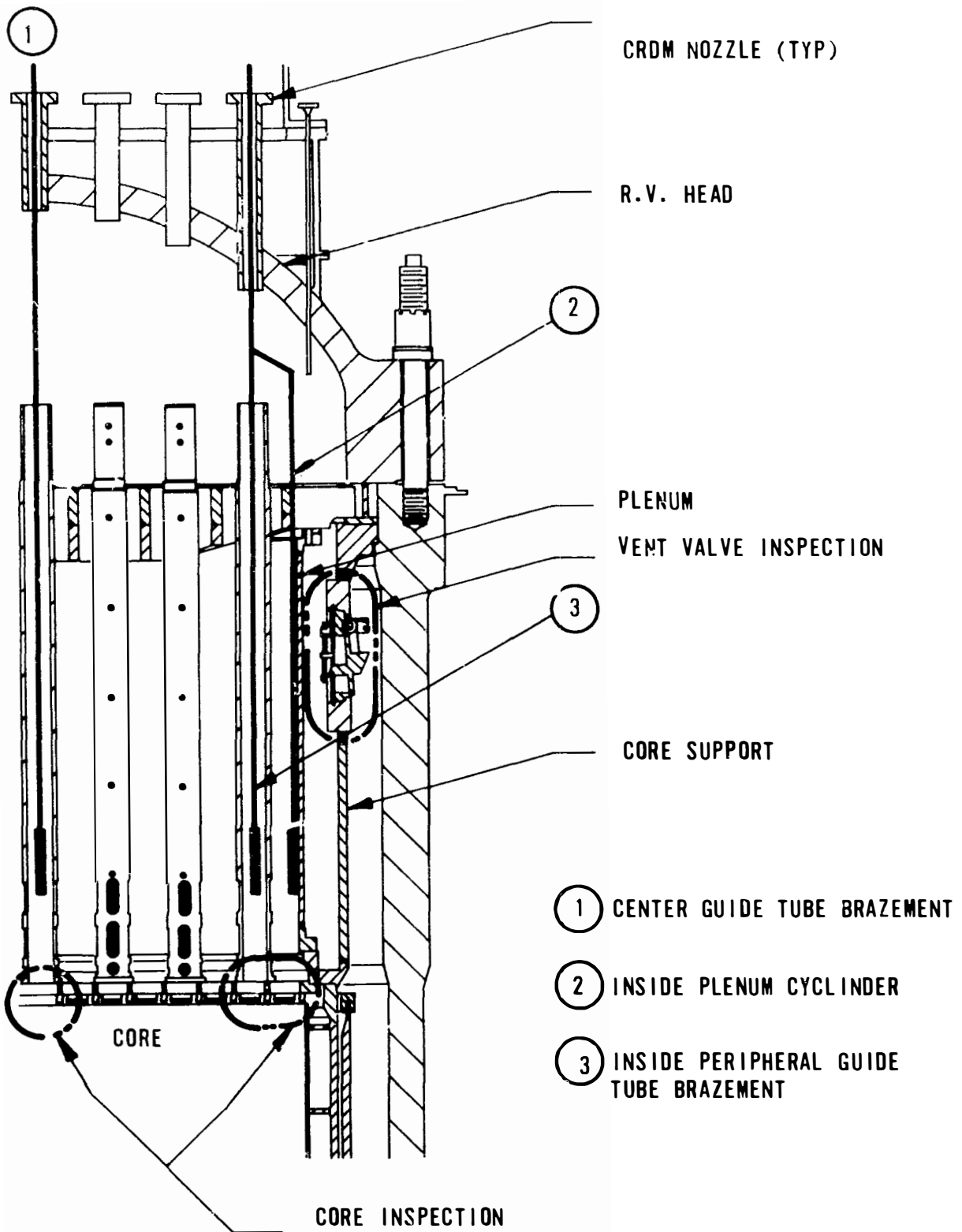

Figure 2-3. Inspection Locations



3. PROJECT DESCRIPTION

Phase III of the project included the final design work on all tools identified, preparation of tool operating procedures, manufacture or procurement of the tools and equipment, and demonstrations of the operation of selected tools on a suitable mockup.

3.1. Penetration Selection

A detailed evaluation of the potential access points into the RV was performed during Phase I. The evaluation was limited to access points into the upper head of the reactor vessel.

Two primary objectives were considered in performing the access evaluation:

1. To allow access for inspection equipment, including auxiliary lighting.
2. To allow access for attachment of an RV head purge system to provide an inflow or air through other penetrations.

Optional objectives were also considered in performing the access evaluation:

1. To allow access for a water level sensing system.
2. To allow access for potential radiation monitoring equipment.
3. To allow access for sampling equipment.

For each of these objectives, criteria were established as a basis for penetration selection. These criteria are listed below.

1. As a minimum, inspection equipment must be capable of viewing the following areas:
 - a. The general area in the upper head, including the plenum cover and control rod guide tubes.
 - b. Inside the plenum between the plenum wall and control guide tube down to and including the upper grid assembly in one quadrant of the vessel.
 - c. Vertically down through a control rod guide brazement to the top of the fuel assembly.

degree of distortion. If the temperatures were as high as 2100F, the rod guide braze material could have begun to melt. If higher temperatures were experienced, the male coupling on the end of the leadscrew assembly could be fused or deformed and may not uncouple from the spider. Some degradation of both components is expected due to the initial thermal gradients and subsequent environment.

An alternate procedure for removing a CRDM was developed which involved removing the stator, unbolting the housing from the RV control rod drive flange, raising the housing to obtain clearance, and cutting the leadscrew. The stator could first be lifted off, using either the standard or the contingency tool.

An access hole could be cut in the service structure as shown in Figure 3-11. The structural aspects of cutting such an opening have been evaluated, and no strength or stability problems were identified. The material is 0.75-inch-thick carbon steel. Either plasma-arc, gas torch or abrasive cutting could be used. Abrasive cutting would reduce potential airborne contamination but may take much longer.

Once the access hole through the service structure is established, removal of the CRDM bolts may proceed. After bolt removal, the CRDM flange is separated a few inches from the vessel flange, exposing the control rod leadscrew support tube and the immovable leadscrew. The leadscrew and support tube could then be cut with the plasma torch. The CRDM motor housing and the upper end of the leadscrew could then be removed to a designated laydown area. Figure 3-12 is a cross-sectional view of the CRDM.

To proceed with the inspection at this point it is necessary to uncouple (separate) the leadscrew assembly from the control rod spider. The access is limited by the 2.765-inch ID of the CRDM nozzle and 1.5-inch outside diameter (OD) of the remaining leadscrew. Numerous leadscrew separation options were investigated and are listed below. Based on the geometric and structural considerations, all but two of the eleven options investigated were discarded as impractical.

Figure 3-11. CRDM Access Hole in Service Structure

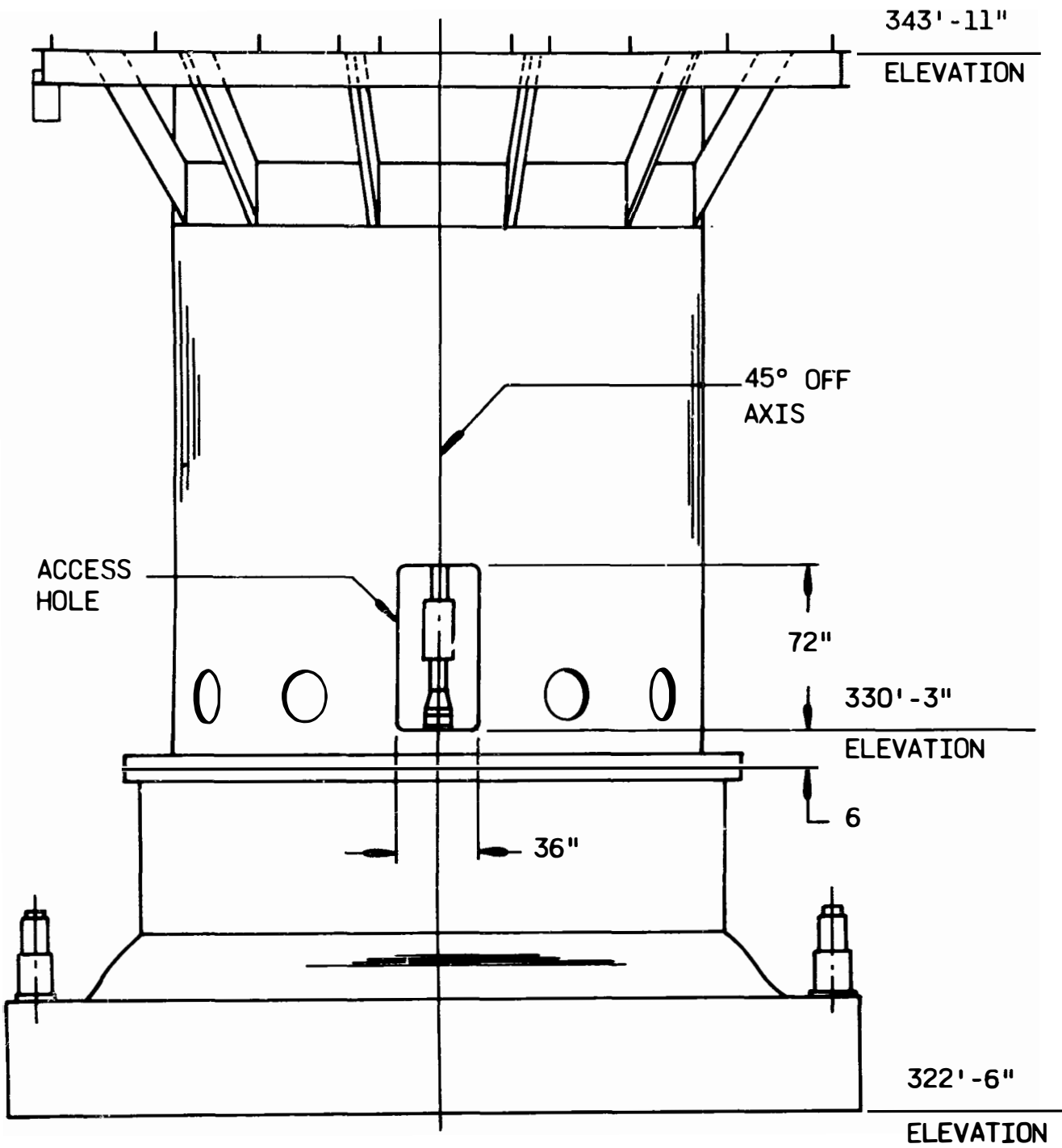
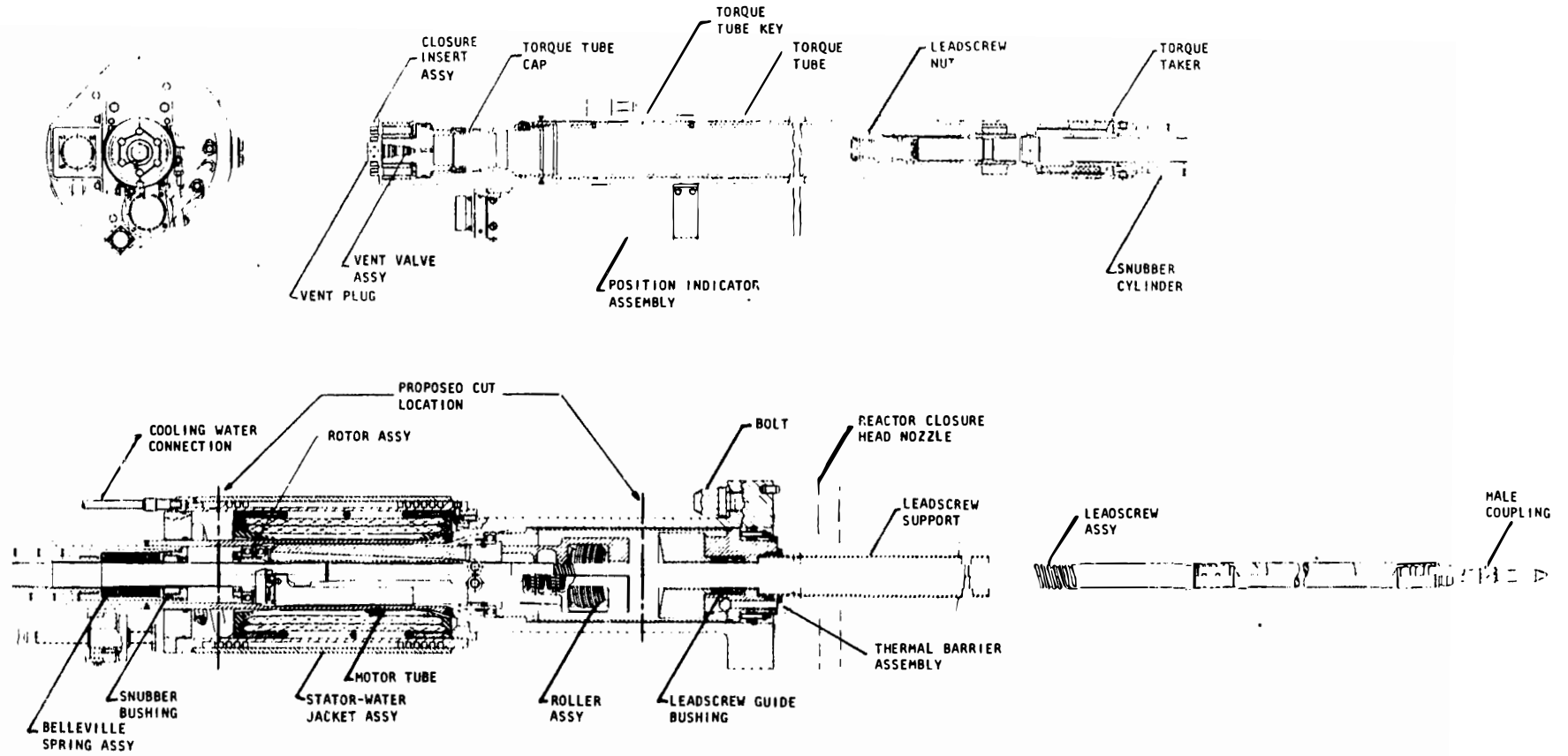

Figure 3-12. Control Rod Drive Mechanism



3-18

Option	Reason not practical
1. Torch cut (gas)	Geometric constraints limit the size of the torch.
2. Electric-arc cut, electron discharge machining	Power levels required and geometric constraints on tooling make this impractical.
3. Mechanically cut (cutting tools, hydraulic shear)	Geometric constraints on tooling and the difficulty in accurately controlling the feed speed.
4. Chemically cut (acid, etc.)	The time required was considered excessive.
5. Chemically machined	It is not practical to establish anodic-cathodic reactions since all metal structures in the RV and the RV itself are electrically connected to the leadscrew.
6. Hydrogen embrittlement	It would be difficult to maintain a hydrogen environment; it could be explosive, slow, and could produce unreliable results.
7. Thermal shock	It would make the leadscrew brittle and would still require impact to break.
8. Freeze (nil ductility)	Essentially no nil ductility temperature in 17-4 pH material.
9. Heat-soften	It is conceivable to heat the leadscrew to reduce stress levels; however, problems in heating the leadscrew inside the RV seem unpractical.
10. Twist apart	
11. Pull apart	

As shown in Figure 3-13, the leadscrew assembly comprises four sections connected at three locations by pairs of stainless steel pins held in place by sleeves. The relative material strengths of the components are listed in Figure 3-14.

Options 10 and 11 were investigated further and calculations were made to evaluate the loads required. The results are shown in Figure 3-15. The 500-ft-lb of torque necessary to shear the pins could be applied. However, due to the

Figure 3-13. Leadscrew Assembly

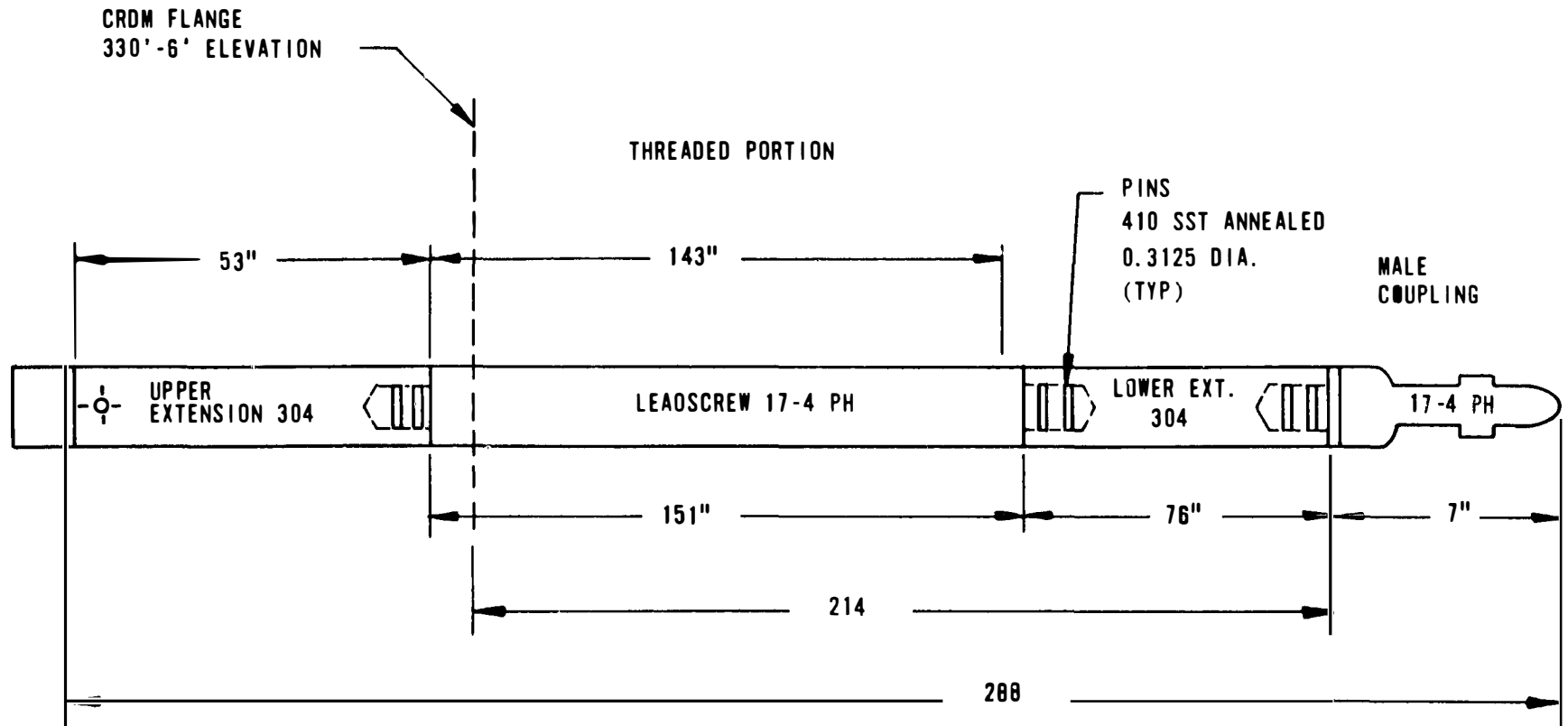

3-20

Figure 3-14. Relative Strengths^(a)

<u>Material</u>	<u>Strength, psi</u>	
	<u>Ultimate</u>	<u>Yield</u>
304 annealed	85,000	35,000
410 annealed	75,000	40,000
17-4 pH H-1100	140,000	115,000

Note: Best estimate of current properties:
No significant change due to transient.

(a) Source: Mark's handbook.

Figure 3-15. Forces Necessary to Separate Leadscrew

Summary of Loads to Separate Leadscrews (Calculated)

Twisting torque to shear pins, ft-lb	500
Separation force to shear pins, lb	11,500
Torque to shear off teeth on coupling, ft-lb	>3,000
Torque to twist off shaft (SS 304 annealed), ft, lb	>1,900

Note: Assumes no significant change in metalurgical properties due to transient.

uncertain condition of the spider and brazement, it was not possible to predict the point of failure. A mockup test of the twist separation was attempted with prototype equipment. The control rod poison tubes bent in the control rod spider and ultimately the spider-to-pin-support arm weld broke. This allowed the leadscrew to turn without releasing from the spider. This method was therefore not accepted.

The accepted method to obtain a separation is shearing the connecting pins by pulling the leadscrew assembly apart. The separation force is estimated to be approximately 6 tons. To apply a force of this magnitude without withdrawing the control rods requires an equal reaction force. A thick-walled pipe could be inserted around the leadscrew to the hub of the spider assembly as a hold down while the jacking force is applied. A block clamp would be placed on top of the leadscrew to transmit force to the leadscrew. Separation of the leadscrew assembly upon the application of force would take place at either one of the lower two pinned connections. Figure 3-16 illustrates the location of the pins. Figure 3-17 is the conceptual design of the tool for shearing these pins.

After the first CRDM and leadscrew are removed, subsequent leadscrews that fail to uncouple could be cut inside the head using the in-head cutter. The plasma arc torch could be lowered through an open nozzle and used to cut adjacent leadscrews between the leadscrew support tube and the upper end of the control rod guide brazement.

The plasma arc torch manipulator was designed to fit through a CRDM nozzle and reach over to an adjacent leadscrew located approximately 12-inches away. The torch could then cut the adjacent leadscrew. This method of separation should reduce both separation time and man-rem exposure. Figure 3-17 shows a conceptual design of this cutting method.

3.4. Other Access Methods

Cutting a special hole in the RV head, either by enlarging the existing thermocouple hole or making a separate penetration was evaluated. The RV head is 7-inch thick carbon steel clad with 0.1875-inch stainless steel. The enlarged hole could follow the existing vertical centerline of the thermocouple penetration. A new penetration could be made radially to reduce stress concentrations. The diameter of each penetration would depend on the exact locations of the holes

Figure 3-16. Leadscrew Puller/Separator

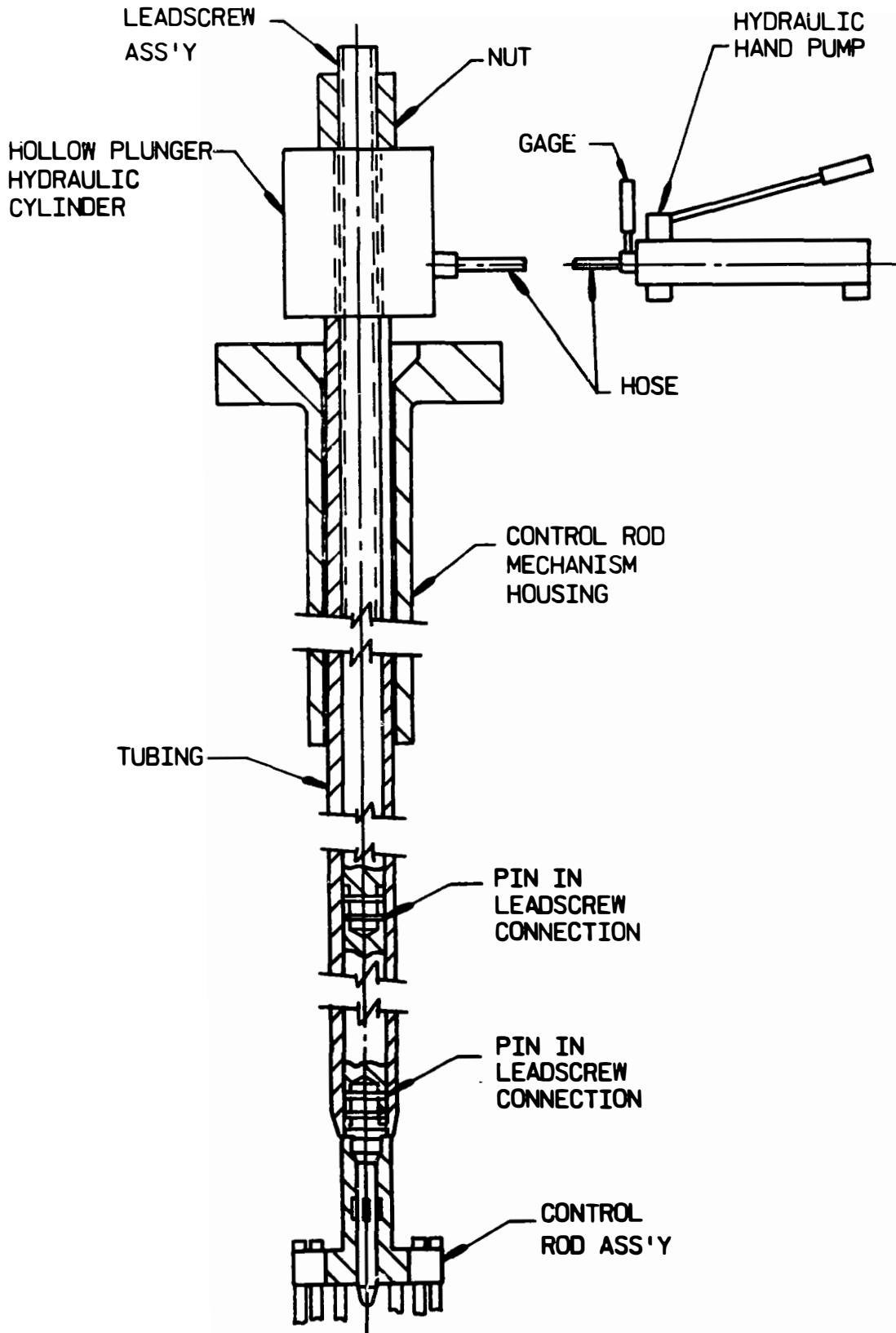
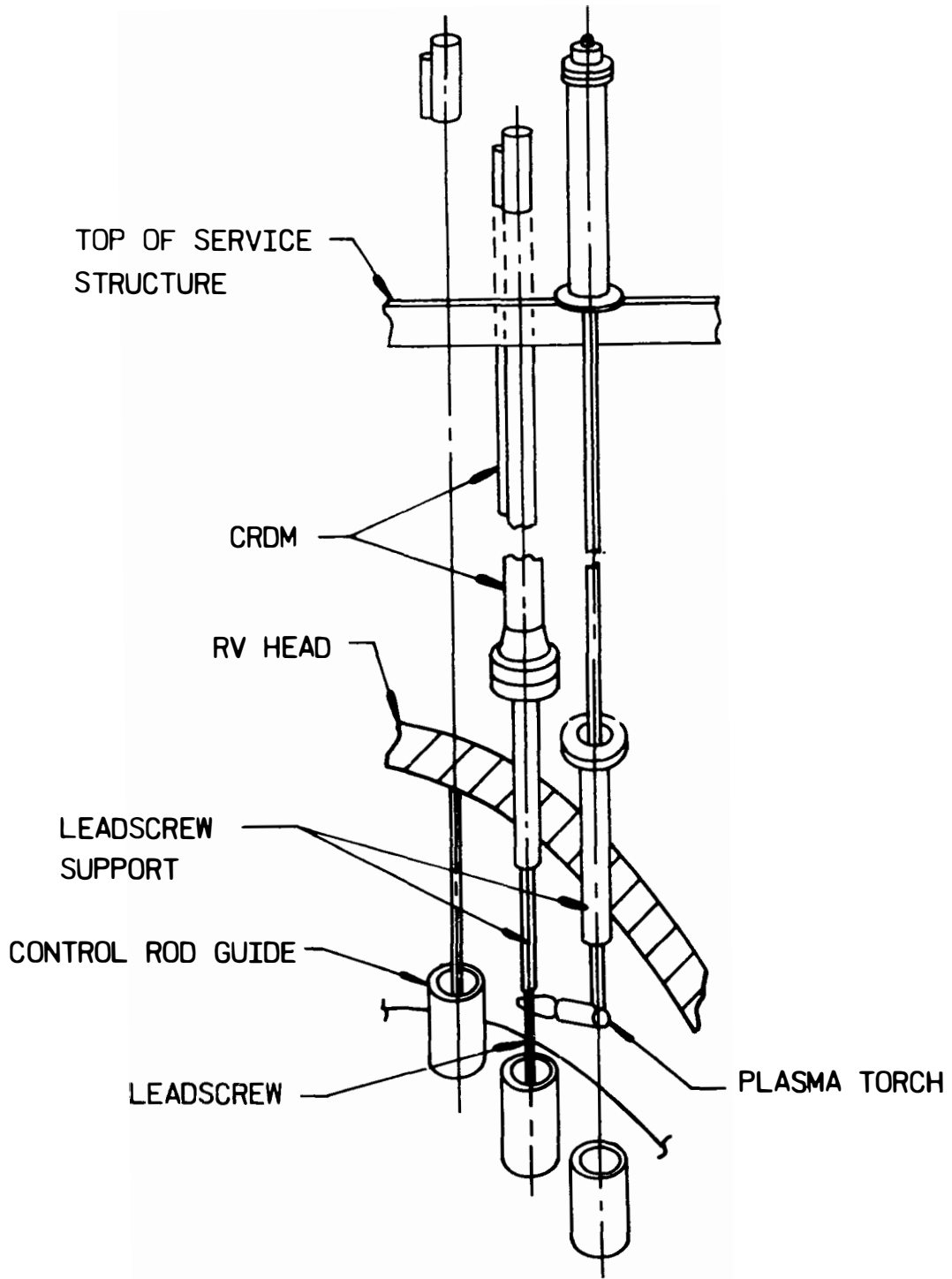

Figure 3-17. In-Head Leadscrew Cutter



and would be on the order of 2 to 4 inches. Tooling could consist of boring equipment mounted on a template bolted to the head by drilled and tapped holes. For the new penetration, a pilot hole could first be made using a magnetic base drill. In both instances, the hole could be cut using progressively larger boring bars. Cutting such a hole in the field at TMI-2 would be a lengthy process and would involve excessive man-rem exposure. The subsequent repair of such a hole would present three major problems:

1. Stress relief.
2. Protection of exposed carbon steel surfaces.
3. Structural integrity of the pressure vessel following repair.

Evaluating these problem areas resulted in the conclusion that, although such a penetration could be made and repaired, it would be considered only as a last resort and would be further evaluated at a later date if existing penetrations could not be used.

3.5. Inspection Technique

The objective of this inspection is to obtain information on the condition of the reactor internals and the top of several fuel assemblies, as well as the extent of damage and debris distribution inside the reactor vessel. Three criteria were used in evaluating different inspection techniques:

1. Results available.
2. Physical limitations.
3. Environment.

For the results, the following characteristics were considered:

1. Resolution — The system should have sufficient resolution to accurately represent complex shapes of damage or unusual findings.
2. References — The inspection system should be position-referenced, either through a positive position control system or have a field of view large enough so that enough points of reference are included to define the location.
3. Recordable output — The inspection results should be accurately recorded either by hard copy output, photographs, or video tapes.

For physical limitations, the following characteristics were considered:

1. The inspection probe must operate at least 40 feet from the control unit.
2. The inspection probe must be capable of passing through a 2.765-inch-diameter opening.

3. The rigid length of the probe should be minimized to facilitate ease of entry via a complex entry path.

For environment, the following conditions were considered:

1. Maximum underwater depth of 40 feet.
2. Maximum water temperature of 150F.
3. Radiation levels up to 1000 R/h.
4. No light.
5. Possible opaque water.

Two types of systems were considered to meet these criteria — video and ultrasonics. Research on the present ultrasonic suppliers determined that no system was currently available that could meet the inspection criteria. A system concept was formulated as a basis for evaluation.

The conceptual system would include a foldable transducer array, a control unit, and a computer for processing the returning information and providing an output to a graphic display or hard copy unit. The ultrasonic system would require positive array positioning. This positive positioning of the array would be required since ultrasonic transducers can transmit and sense at only one point at a time. To build an image, the transducer array must be moved in a controlled path to trace out a line of data. This controlled path can be designed to trace out an orderly scan of the desired object. In the conceptual system, the control system would have to position and unfold the probe and then be able to move the transducer array accurately enough to obtain a fine resolution scan. A control system that could do this would be complex and would have to be developed along with the overall ultrasonic system. The image, constructed by sound reflected from surfaces only, would be topographic and would not show shadow effects or surface appearance. The principal advantage of the ultrasonic system would be its ability to operate in an opaque environment.

Three video systems were compared; the results are given in Table 3-1. The video systems were all capable of meeting the criteria established for the inspection system with the exception of operating in opaque water.

Table 3-1. Camera Specification Table

	<u>Diamond ST-6¹</u>	<u>Fersneh R-93 TM</u>	<u>Westinghouse² ETV 1250</u>
Diameter × length (with connector), in.	1.125 × 14.5	1.5935 × 11-5/6 (without connector)	1.25 × 13-2/5
Resolution, lines	800	550	550
Gray scale, shades	10	10	10
Focus range	0.5 in. to ∞	13 mm to ∞	1 in. to ∞
Remote focus	Yes	Yes	Yes
Automatic light compensation	Yes	Remote iris control	Yes
Straight ahead lighting power, watts	<20	150	40 integral
Right angle lighting power, watts	20	150	150
Newvicon tube available	Epicon	Yes	Yes
Maximum radiation field, 10 ⁶ R/h	5	Unknown	2
Cumulative exposure limit, R	10 ⁸	1.6 × 10 ⁸	10 ⁸
Temperature range, C	-20 to +70	-25 to +60	+60
Lens, mm	16	11	16

Notes: 1. Right angle viewing attachments not developed and tested.

2. Camera system and all attachments first marketed May 1977.

As a contingency in the event of a murky water situation, some conceptual designs for murky water viewing attachments were tested. These designs were tested on an actual underwater camera (the Westinghouse ETV 1250) in a mixture of tap water and common scil. Visibility was measured at about 2 inches.

The first idea tested was the use of a fresh water jet with a clear water viewing plume intended to provide constant flushing in front of the camera. The flushing action sucked debris into the plume and the turbulence in the water reduced the effectiveness of the camera lights. The end result of using the plume was decreased, not increased, viewing capability.

Another concept tested employed bright lights near the camera. This method was unsuccessful because the light reflected off the suspended particles and created glare.

The concept that showed promise was an inflatable bag. In this concept, a clear plastic bag is slipped over the front of the camera and inflated with a constant supply of fresh water to provide a viewing space of clear water between the camera lens and the object being viewed. Vent holes are placed around the bag for discharging the clear water. This concept provides acceptable viewing as long as the bag is in contact with the viewing surface. A conceptual sketch of the inflating bag system is shown in Figure 3-18.

Demonstrations of the Westinghouse ETV-1250 and the Diamont ST-6 were conducted at B&W in Lynchburg. The Westinghouse system appeared to satisfy the criteria better during the demonstrations. The integral lighting system was judged superior in both angle and straight ahead viewing. The Westinghouse system also appeared to have a better arrangement for changing viewing accessories (threaded connections versus set screws). The ST-6 camera has a higher resolution specification, 800 versus 550 lines; however, the ETV-1250 produced a clearer picture during the demonstration. Unlike the ETV-1250 system, the right-angle viewing attachments for the ST-6 system have not yet been fully developed and tested. Other differences between the cameras were minor.

The FERNSEH system was judged unsuitable because of larger camera size, larger size of the forward viewing attachment, and discontinuities in the surface of the right-angle viewing attachment, which could cause the camera to hang up.

Figure 3-18. Concept for Murky Water Viewing

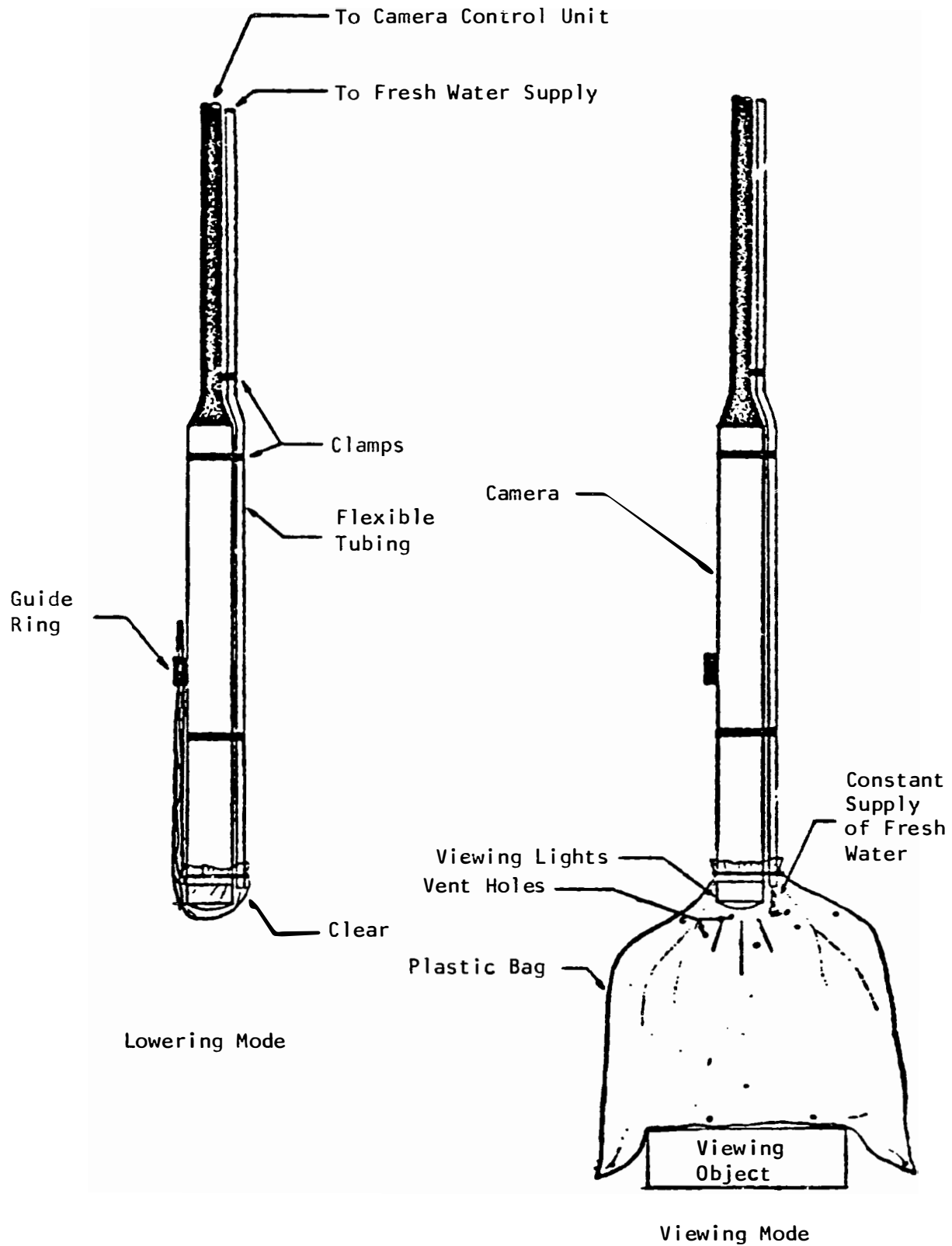

None of the systems considered had sufficient integral lighting with the camera. Auxiliary lighting will be necessary for general area coverage. These lights could be fabricated from existing components to meet the access and environmental requirements of the inspection process.

3.6. Manipulators

Manipulators are required to maneuver three types of devices within the RV during inspection operations:

1. Cameras – manipulator must be able to move a camera to three desired points of observation:
 - a. Tops of peripheral fuel assemblies – To reach this area the camera must travel from the point of entry, around the edge of the plenum cover, then down along the inside of the plenum cylinder to a point directly above the peripheral fuel assemblies.
 - b. Interior of control rod brazements – The camera can be lowered straight down from the CRDM nozzle into the guide tube brazements.
 - c. Top of plenum cover – The camera can view the plenum cover in the available open area below the entry point.
2. Auxiliary lighting – the manipulator should be able to position the auxiliary lighting in the upper head region for general illumination. It should also be capable of positioning auxiliary lighting inside the plenum cylinder to a point above the fuel assemblies and between the plenum cylinder and core support shield.
3. Sampling equipment – this manipulator must carry the swipe system over a system over a section of the plenum cover to collect swipe samples of the plenum cover.

In addition to maneuvering its particular device to a desired location, each manipulator should:

1. Fit through the available penetration in the closure head.
2. Not encounter interference from existing structures within the closure head.
3. Allow the connecting cable for the device to feed freely for both entry and exit operations.
4. Operate reliably.
5. Allow manipulator control from outside the vessel head penetration.

6. Allow coordination with visual observation equipment for placement, sample gathering, etc.
7. Be salvageable if camera or lighting becomes stuck beyond removal.

The following options were considered for manipulators:

1. A hinged arm.
2. A hinged tube.
3. A hinged tube with provisions for housing the camera.

In each case, the lower arm of the manipulator is raised and lowered by a deployment cable. The camera or light would be lowered through the manipulator by handling its electrical cables.

Based on the established criteria and an evaluation of the advantages and disadvantages of each type of manipulator, the following conceptual designs were chosen for each operation.

Camera — A hinged tube with a camera recess, which allows a maximum length of the lower manipulator arm, was chosen. This longer lower arm allows the greatest lateral movement and gives a larger angle for a given offset. This larger angle reduces cable drag and allows controlled payout of the camera cable.

A method for canting the camera at a slight angle (0 to 30°) in a given direction is required. By using a draw cable attached to the camera head and by rotation of the camera cable, this manipulation could be achieved. The conceptual design is shown in Figure 3-19.

Auxiliary Lighting — A hinged tube with or without the recess capability (Figure 3-20) could be used for the auxiliary lighting. A tube was chosen over a closed, hinged arm because enclosing the electrical cable in a tube reduces the risk of fouling in the manipulators.

Debris Sampling/Swipe Sampling — For this operation, a hinged tube with an additional weighted arm connected at the bottom of the lower arm was selected (Figure 3-21 and 3-22). This arrangement allows movement over the plenum cover in the vicinity of the CRDM nozzle (radius approximately 25 inches). The weighted arm, which will hang vertically, will allow controlled positioning of the swipe sampler over desired areas of the plenum cover.

3.7. Radiological Boundary Equipment

A radiological boundary should be provided to prevent gases inside the vessel from exiting to the operating platform during inspection operations. A RV

Figure 3-19. Option Using CRDM Tube From SSS

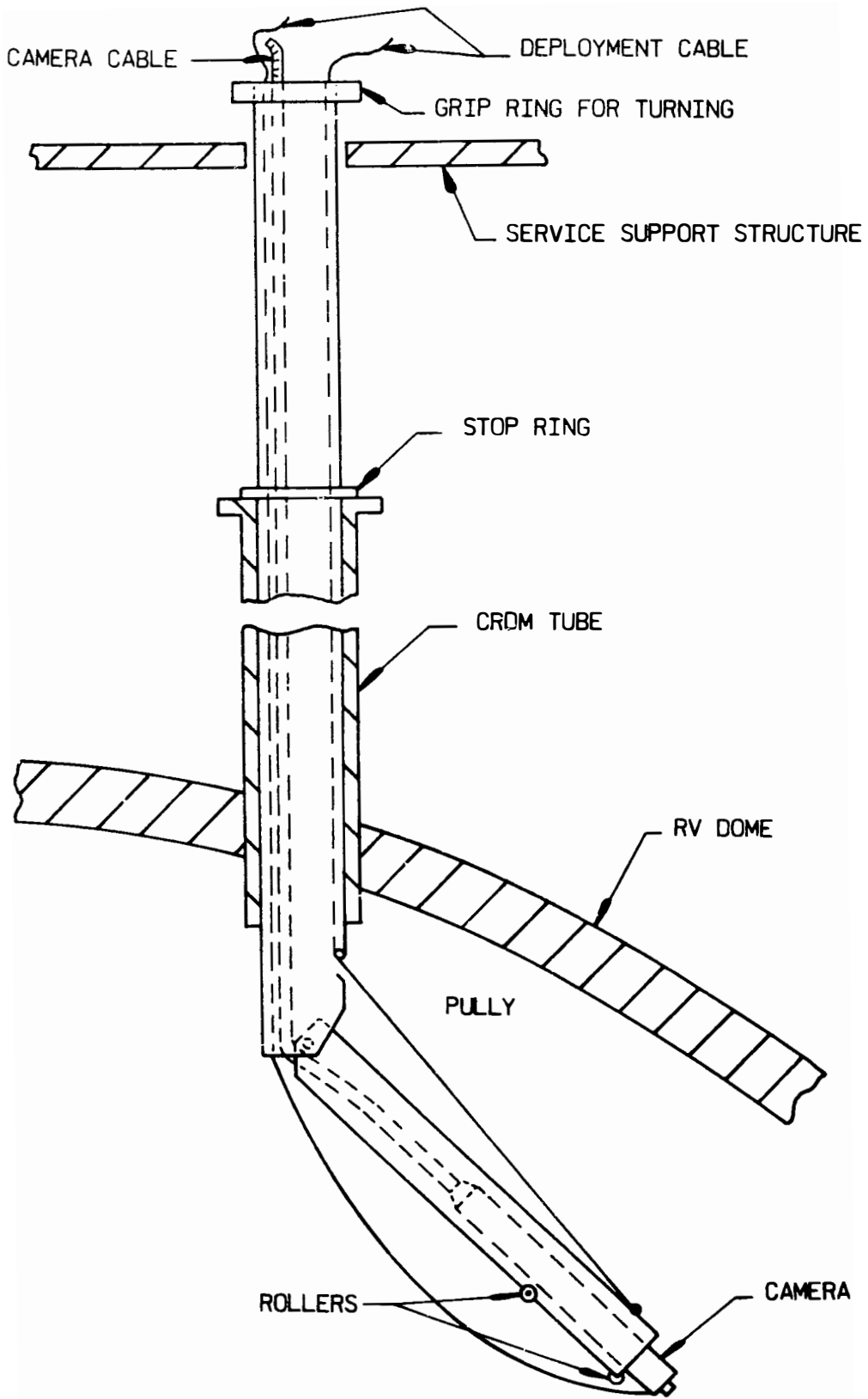

Figure 3-20. Hinged Tube Manipulator for Auxiliary Lights

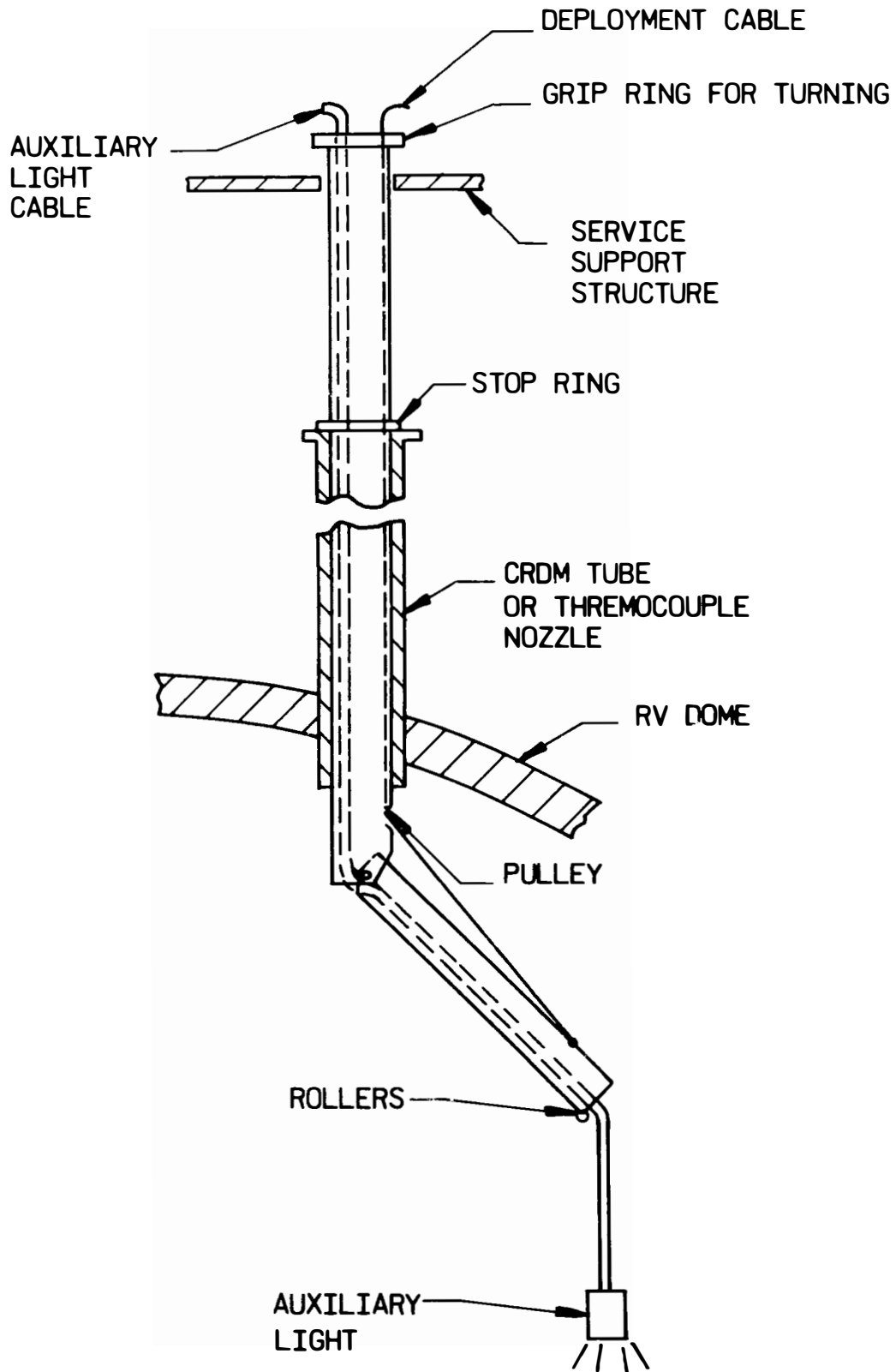

Figure 3-21. Manipulator for Swipe Sampling

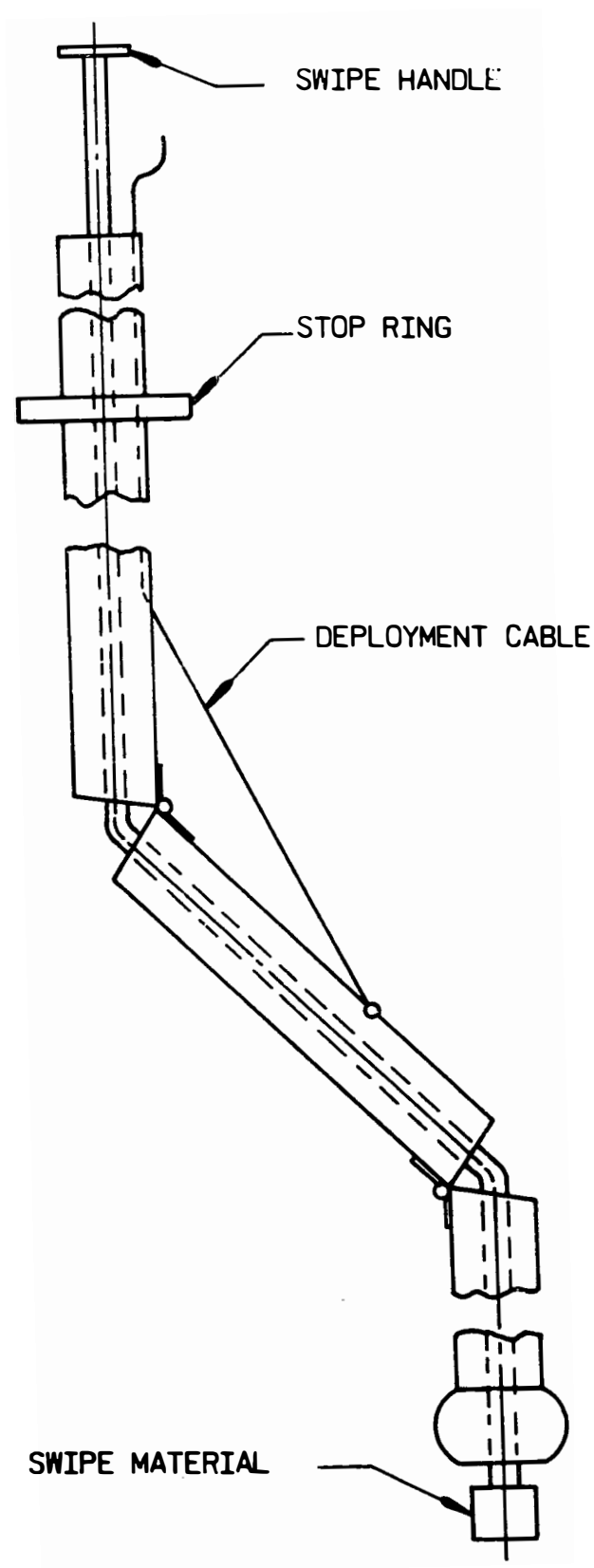
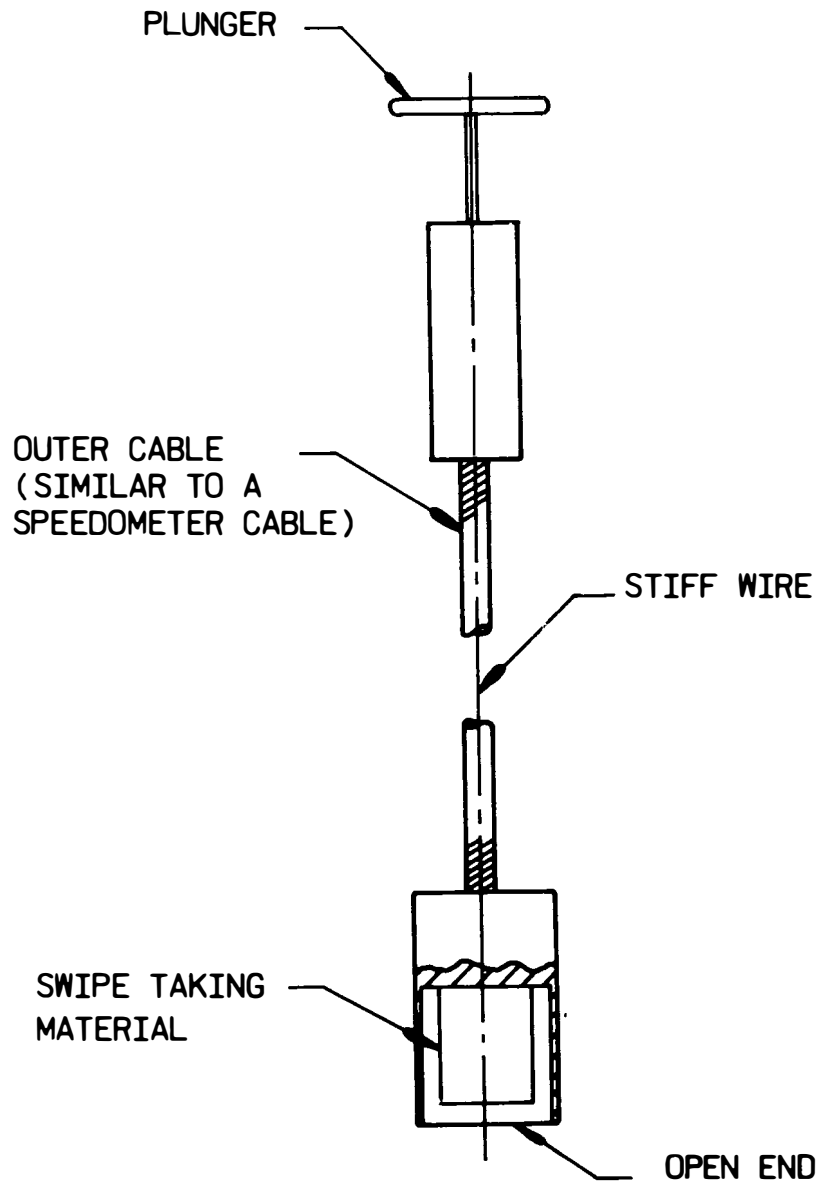

Figure 3-22. Swipe Sampler



purge system is provided to maintain a continuous air in-flow through all penetrations that are directly open to the reactor building. This system should be capable of maintaining a negative pressure inside the RV with up to three CRDM nozzles open to the environment. The system connects two air pumps in parallel to as many as five thermocouple nozzles by appropriate manifolding. The system discharges into the reactor building ventilation system.

Maintaining the primary water level is critical during the inspection, and it was considered important that the video inspection team be able to monitor this level. A drop in water level could result in a loss of shielding, leading to excessive radiation exposure. A rise in the water level could render the purge system inoperative and result in spillage of the reactor coolant. The water level system provided will warn the operators of inappropriate water level changes and give them time to take proper action or leave the building.

3.8. Mockups

Mockups are required for checkout and testing of the special tooling and procedures developed. These mockups could also be used for training personnel in procedures and the use of the tooling. The Diamond Power Specialty Co. (DPSC) was selected as the primary site for a mockup of the RV and CRDM arrangement. The DPSC test facility includes several full-scale CRDMs used for operational testing. It was also selected because of its overhead room, crane facilities, and platforming needed for mockup purposes. Other smaller mockups are also required to test specific tools. Conceptual designs of these mockups are shown in Figures 3-23, 3-24, 6-7 and 6-10.

3.9. Radioactive Equipment Storage

Storage racks are needed for radioactive equipment removed from the RV during the inspection task. The equipment racks should be designed to pass through the personnel hatch and should be erected inside the building. The radioactive equipment to be stored in these racks is in three categories: (1) reactor components removed to gain access to the inside of the vessel, (2) tools used to remove the reactor components, and (3) special equipment used for the inspection (camera, lighting manipulator, water level system, replacement motor tube, purge system, etc.). These storage racks are not included in Phase II or III.

Figure 3-23. Test Facility Mockup

TO TEST NORMAL & CONTINGENCY TOOLING, MANIPULATORS,
CAMERAS AND LIGHTING, DEBRIS SAMPLING TOOLS

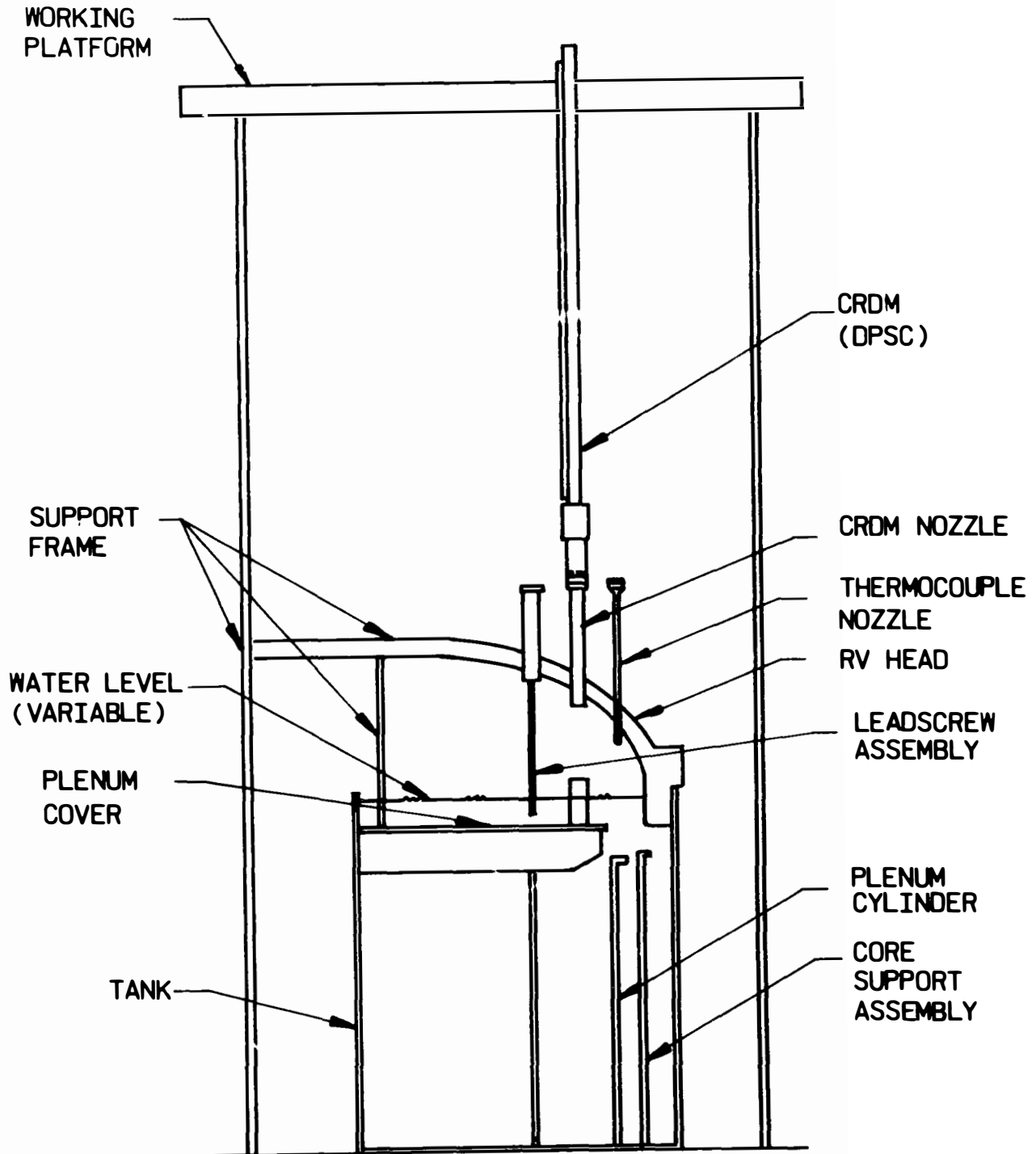
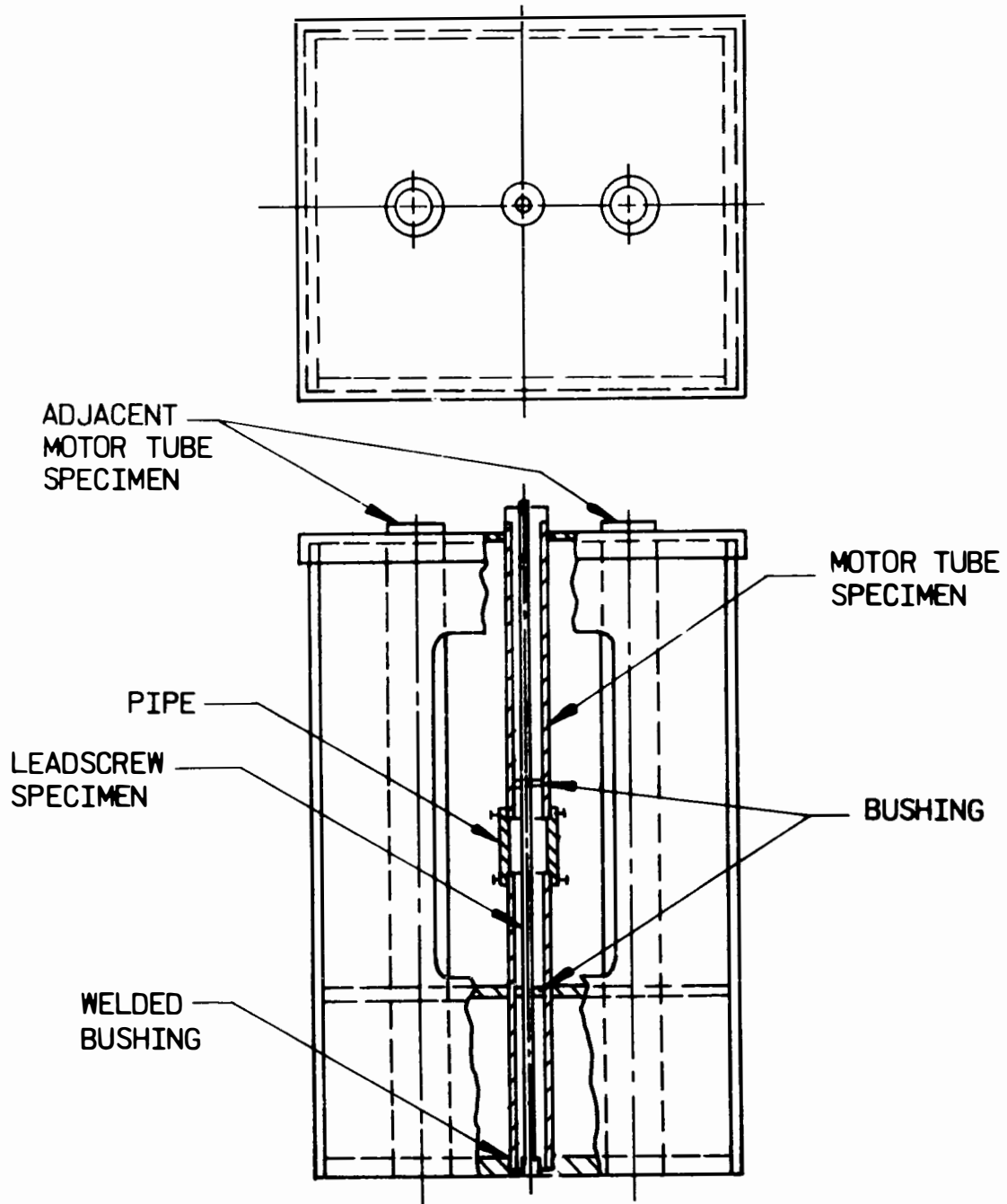

Figure 3-24. Motor Tube/Leadscrew Cutting Mockup



3.9.1. Reactor Component Storage

The major reactor components to be removed are the CRDMs and leadscrews. Racks should be constructed to hold all parts (motor tube, stator, leadscrew, etc.) for up to four CRDMs. Portable shielding, such as lead bricks and lead blankets, may be used to attenuate the radiation from potentially radioactive leadscrews. The leadscrews will have the highest activity as they are removed from the vessel. Leadscrews may be flushed to wash off contaminants. Other CRDM components (motor tube, position indicators, etc.) are expected to have lower levels of activity and, hence, will require only a minimum of shielding.

3.9.2. Tool and Equipment Storage

The plenum swipe tool and the push/pull leadscrew separator will both be immersed in the reactor coolant. Both of these tools can potentially have highly radioactive debris attached. Portable shielding may be used, as necessary, to shield the tools after they have been removed from the reactor. Other tools (stator removal, bolt removal, etc.) should be less contaminated.

The video camera head (including murky water and other attachments) and cabling will also be immersed in the reactor coolant. Since these items will be close to the core, there is the potential for highly radioactive core debris to adhere to the equipment surfaces. Special handling procedures may be necessary once the equipment has been removed from the vessel. Other special equipment, such as manipulators, the water level system, and the replacement motor tube, may also become slightly contaminated. Racks or containers should be used (with temporary shielding if necessary) to store these items.

3.10. Interface Requirements

The following interface requirements have been established and will be needed to support the inspections:

1. Training — The site should supply all security, health physics, and other training required for operating personnel to gain site/reactor building access. Technicians involved in the inspection will require training.
2. Electric power — The equipment provided will require ten 20-amp, 110-volt, single-phase circuits; one 100-amp, three-phase, 480-volt circuit; and two 50-amp, three-phase, 480-volt circuits. These two 50-Amp circuits should not be supplied from a common circuit.

3. Portable shielding, personal radiation monitoring devices, anti-contamination clothing, and forced air respirators – should be supplied as well as any other radiation protection equipment required for site health physics procedures.
4. Health physics coverage – Supply sufficient health physics personnel to provide continuous coverage during the inspection task.
5. Draindown equipment and personnel – Supply all personnel and equipment to drain the RV down to above the plenum cover.
6. Personnel – Supply all craft personnel consistent with site/union agreements.
7. Audio communications – Supply an acceptable means for inspection personnel to communicate with personnel outside the reactor building.
8. Service structure access – Supply an acceptable means to move personnel and equipment to the top of the service structure. All currently proposed equipment can be hand-carried or hoisted to the operating floor. The site should also supply an acceptable means for a person to climb or step down onto the RV head outside the service structure to remove the thermocouple flanges. The site should also supply an acceptable location where a 4 × 4-foot pallet can be hoisted from the 305-foot level to the 347-foot level.
9. Normal CRDM tooling – Supply all normal CRDM tooling.
10. Laydown area – Supply an acceptable laydown area for the storage racks.
11. Tool assembly area – Supply an area inside the reactor building designated for assembling CRDM tooling and inspection equipment. An area on the 347-foot level, approximately 10 × 20 feet is required.
12. Air supply – Provide the normal air supply for the normal CRDM tools, which require an air source.
13. Storage racks and facilities – Supply acceptable storage racks and facilities consistent with previous items.
14. Sample containers – Supply portable sample containers to handle debris samples and swipes obtained during the program.

4. EQUIPMENT — PURPOSE AND DESCRIPTION

Equipment for the project can be separated into four groups:

1. Support equipment that includes the equipment to provide radiological boundaries for protection of technicians.
2. CRDM removal tools that provide the capability to extract stators and holddown bolts that will not come out by normal means. Also, tooling to provide for separating leadscrews from the control rods.
3. Video inspection equipment, including complete underwater TV cameras and special lighting. Also included are a murky water viewing attachment for underwater viewing in turbid water and manipulators to position underwater cameras.
4. A swipe tool to obtain samples of material present on the plenum cover.

4.1. Support Equipment

Several devices have been developed to maintain radiological barriers and supplement existing health physics measures. A purge system prevents the escape of radiation gases and airborne contamination from inside the RV during inspection procedures. Manipulator support tubes to permit access to the RV at a safe distance, closures to seal reactor nozzles during and after the inspection, and a water level sensing system to protect inspection personnel are also included.

4.1.1. Purge System

The purge system is provided to maintain a vacuum of at least 0.1-inch H₂O inside the enclosed volume of the reactor closure head during inspection operations. This vacuum is to be maintained with three CRDMs removed from the head and replaced with manipulator support tubes mounted on the CRDM nozzle flanges. The support tubes will be open to the atmosphere. Maintenance of this vacuum while inspection work is performed ensures that there will be no "out-rush" of contaminated particles or radioactive gases.

Calculations indicate a potential for loss of the 0.1-inch H₂O head vacuum during the 5 to 10 seconds of plasma-arc cutting. Therefore, to ensure that no "burp" of gases occurs, the manipulator support tube openings should be closed during actual in-head cutting of the leadscrews.

Two identical vacuum pumps are included in the purge system. Each pump has its own shutoff valve on the suction side to permit single-pump operation. The second pump is redundant and serves as a backup by manually changing the lever-operated shutoff valves if pump failure occurs. The pumps are connected to a manifold attached by flexible hoses to four thermocouple nozzle flanges. The thermocouple nozzles provide a suction intake path from the vessel head. A vacuum breaker valve is also connected between the manifold and a controller that senses reactor head vacuum through an existing flow path using a fifth thermocouple nozzle (see the purge system schematic diagram included in Figures 4-1 through 4-5). The controller is set to the desired vacuum and automatically opens the breaker valve if the set vacuum is exceeded. When open, the breaker valve is vented to ambient pressure. Valve closing and opening is fast enough that acceptable vacuum control is achieved. Also, with the worst case of four manipulator support tubes open, the air velocity into the tubes is approximately 11 ft/s.

4.1.2. Manipulator Support Tubes

The manipulator support tube (MST) acts as a guide for the manipulator. It also serves as a radiological boundary since it increases the distance that gases and particulates must travel against the airflow caused by the purge system to escape the reactor vessel. The MST will also provide support and guidance for the swipe tool.

Once a CRDM is removed, the MST is positioned on the CRDM flange in its place (see Figures 4-6 and 4-7). The MST is secured by four 1.375-inch hex-head stainless steel bolts. The existing nut ring will be used provided it is not damaged during removal. If damage to the nut ring is excessive, another nut ring will be provided. The nut rings are constructed of stainless steel and accommodate eight bolt holes (see Figure 4-8a). Tooling for nut ring removal or connection has not been provided as part of this task.

Figure 4-1. Purge System

4-3

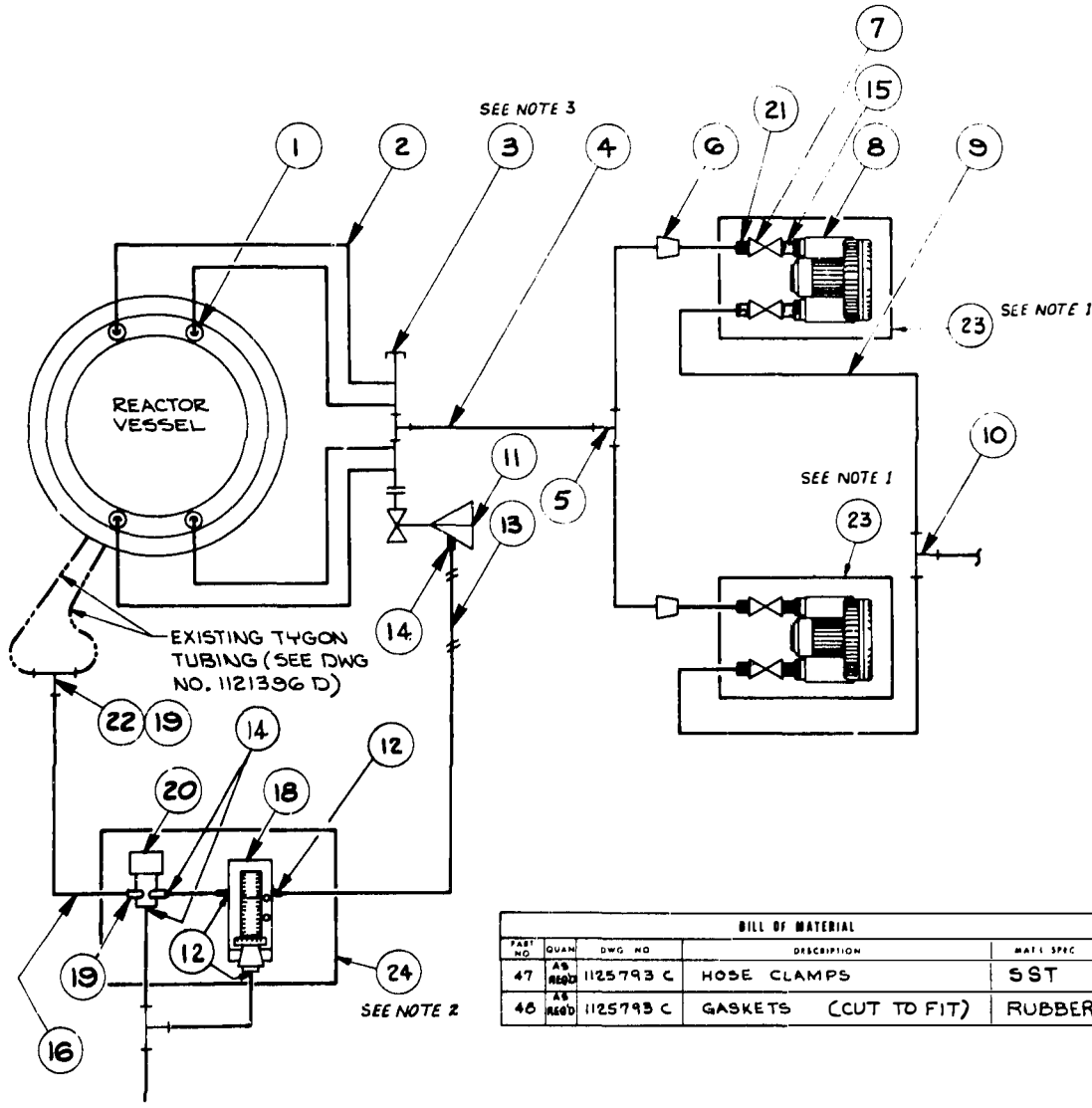

SEE NOTE 3

SEE NOTE 1

SEE NOTE 1

SEE NOTE 2

BILL OF MATERIAL				
PART NO	QUAN	DWG NO	DESCRIPTION	MATL SPEC
47	AS REQD	1125793 C	HOSE CLAMPS	SST
48	AS REQD	1125793 C	GASKETS (CUT TO FIT)	RUBBER

- NOTES:
1. WEIGHT OF SKID & PUMP ASSEMBLY IS 186 LBS.
 2. WEIGHT OF SKID, CONTROLLER & D/P CELL IS 103 LBS.
 3. WEIGHT OF VALVE & MANIFOLD IS 135 LBS.

BILL OF MATERIAL				
PART NO	QUAN	DWG NO	DESCRIPTION	MATL SPEC
1	4	1125798C	SPECIAL THERMOCOUPLE FLG	AS NOTED
2	AS REQD	1125793C	1 1/2" I.D. FLEX HOSE - BUCKEYE	RUBBER
3	1	1125807C	MANIFOLD ASSEMBLY	AS NOTED
4	AS REQD	1125793C	3" I.D. FLEX HOSE - BUCKEYE	RUBBER
5	1	1125800C	3" TEE ASSEMBLY	AS NOTED
6	2	1125810C	3 x 2 REDUCER ASSY	AS NOTED
7	4	1125793C	2" GATE VALVE - B. JENNINGS "APOLLO"	COM'L
8	2	1125793C	FUJI VFCT01A RING COMPRESSOR	COM'L
9	AS REQD	1125793C	2" I.D. HOSE - BUCKEYE	RUBBER
10	1	1126150C	2" TEE ASSEMBLY	COM'L
11	1	1125793C	PNEUMATIC CONTROL VALVE - FISHER # 1052-8550	COM'L
12	3	1125793C	MALE HOSE CONNECTOR - CAJON # SS-2-MHC-4T	SST
13	AS REQD	1125793C	1/4" I.D. HOSE (200 PSI)	RUBBER
14	3	1125793C	MALE HOSE CONNECTOR CAJON # SS-4-MHC-4T	SST
15	4	1125804C	PUMP FLANGE	AS NOTED
16	AS REQD	1125793C	1/2" I.D. HOSE	RUBBER
17				
18	1	1125793C	SYNCRONI INDICATING CONTR. #528 SM WITH 502-MOORE PROD.	COM'L
19	4	1125793C	MALE HOSE CONNECTOR - CAJON # SS-8-MHC-8T	SST
20	1	1125793C	D/P CELL # 15A1 MOORE PROD.	COM'L
21	4	1125809C	VALVE ADAPTER	AS NOTED
22	1	1125793C	TEE - CAJON # SS-8-T	SST
23	2	1125813D	SKID ASSEMBLY	AS NOTED
24	1	1125813D	SKID ASSEMBLY	AS NOTED

Figure 4-2. Manifold and Breaker Valve Assembly

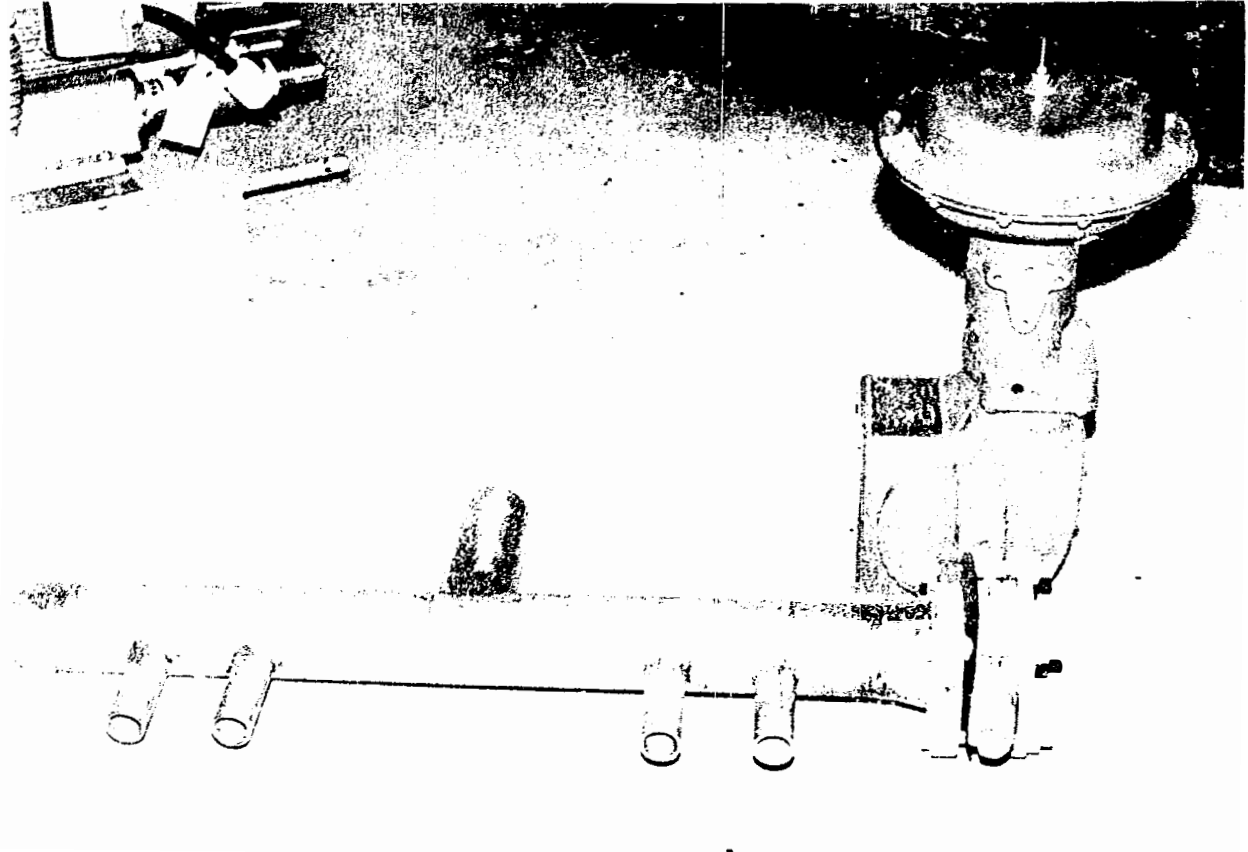

Figure 4-3. Ring Compressor

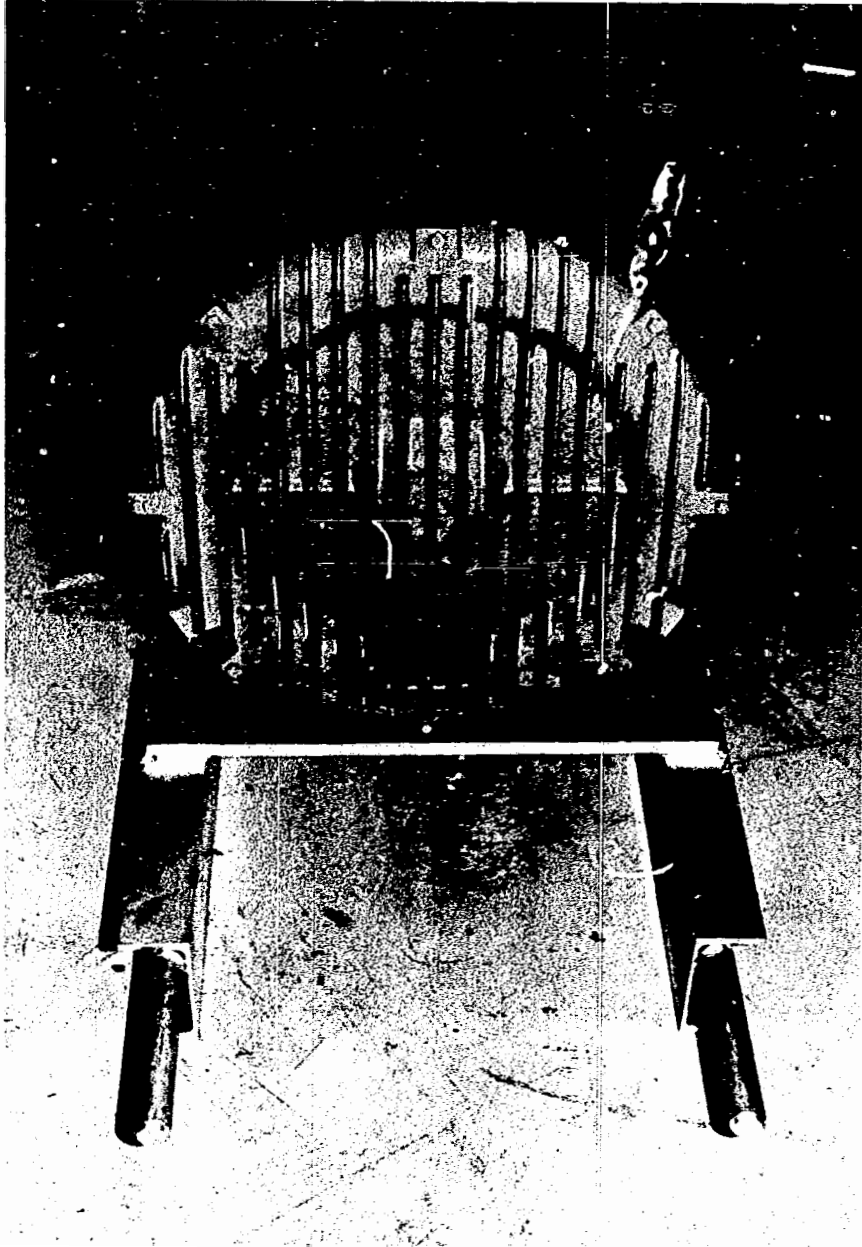

Figure 4-4. Controller and Differential Pressure Cell

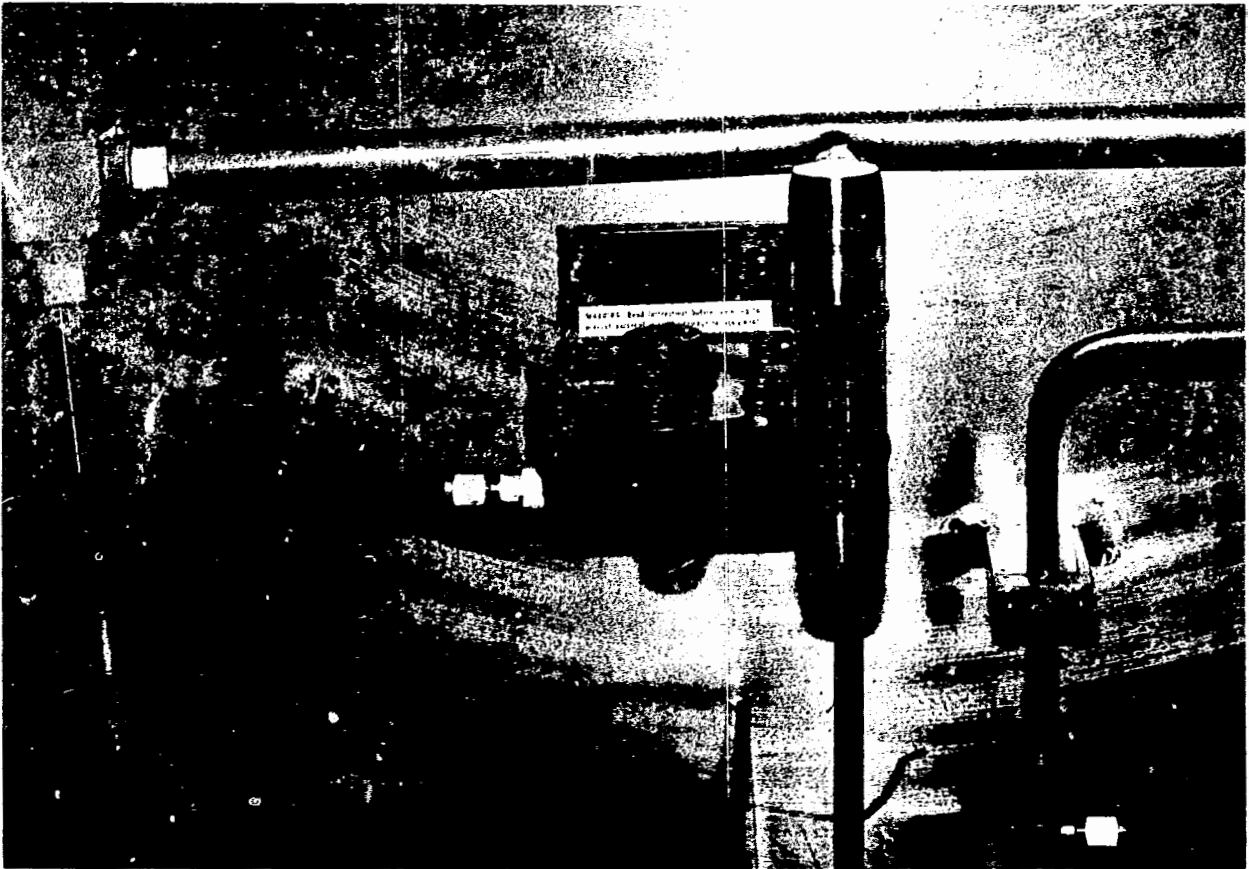

Figure 4-5. Flexible Hoses

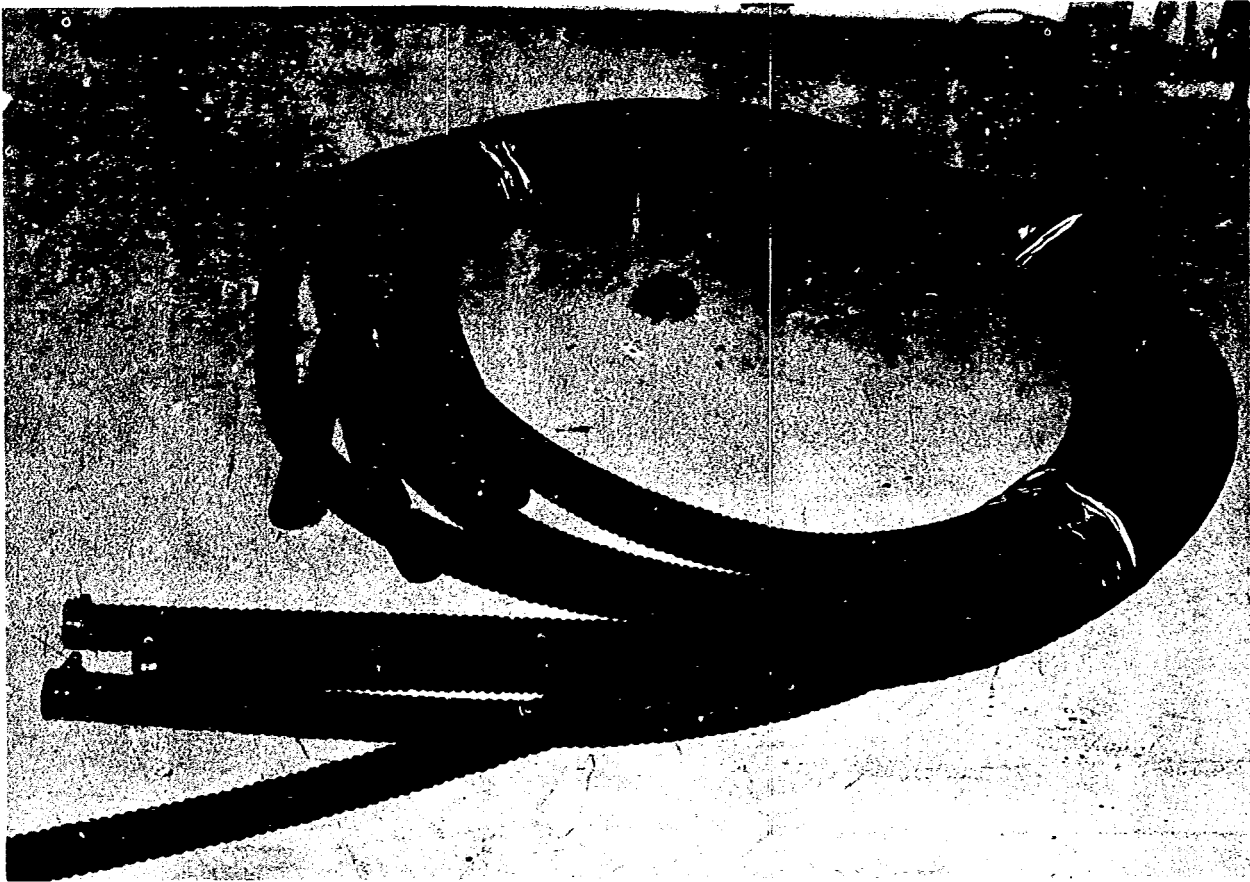

Figure 4-6. Manipulator Support Tubes

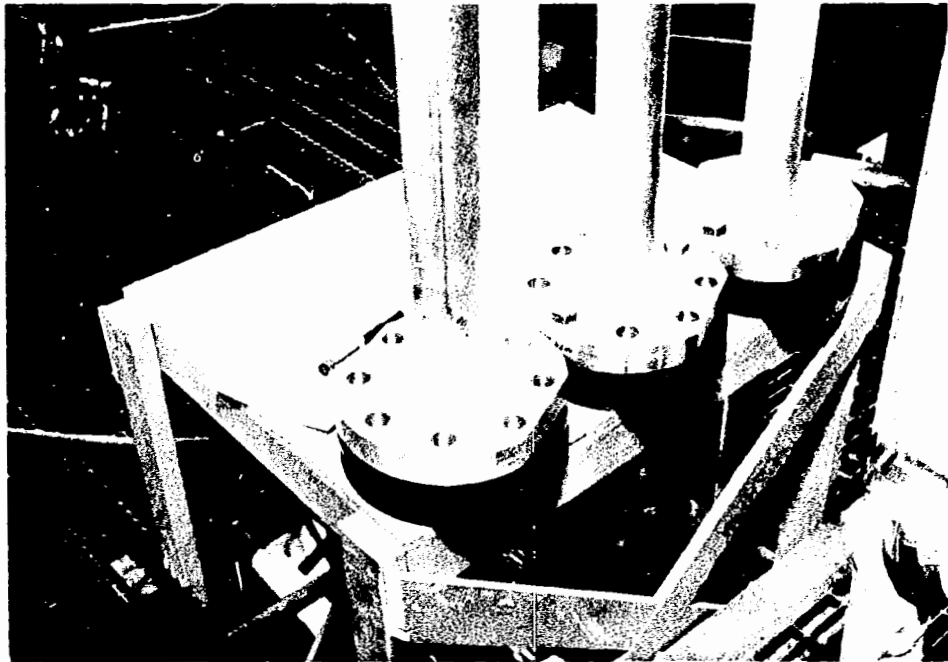

Figure 4-7. Manipulator Support Tube

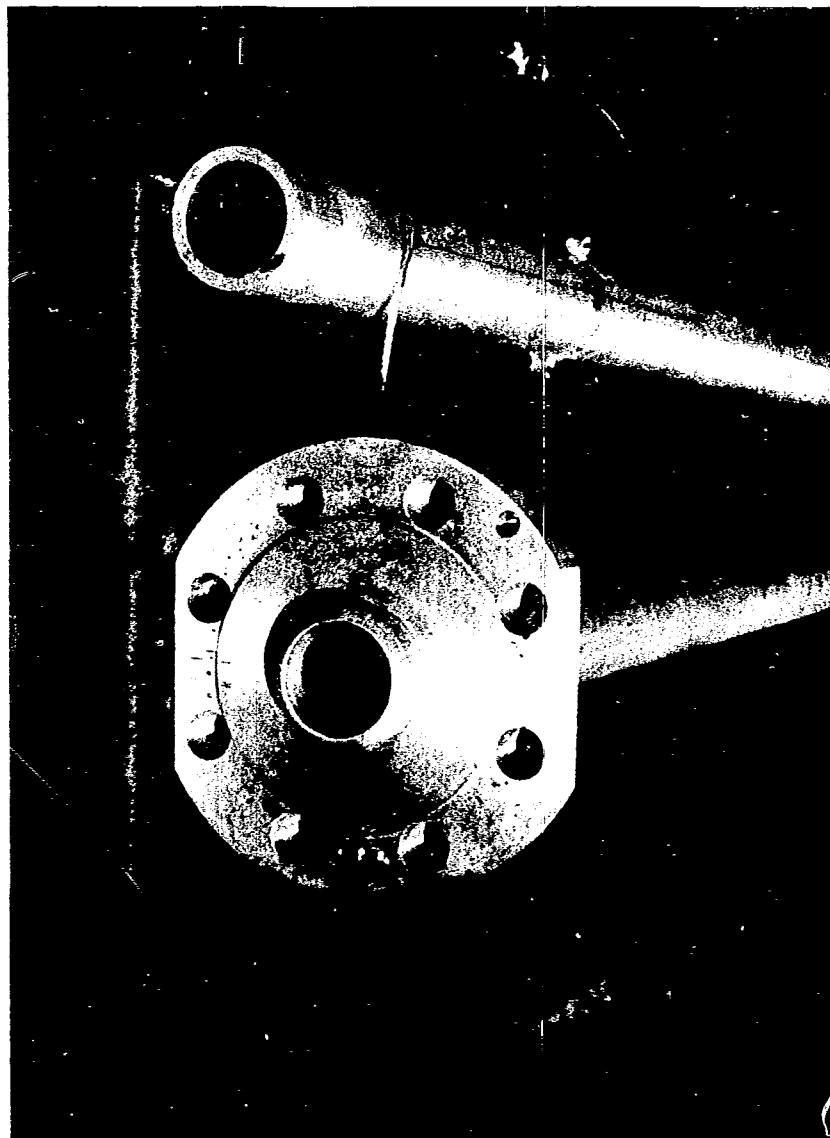
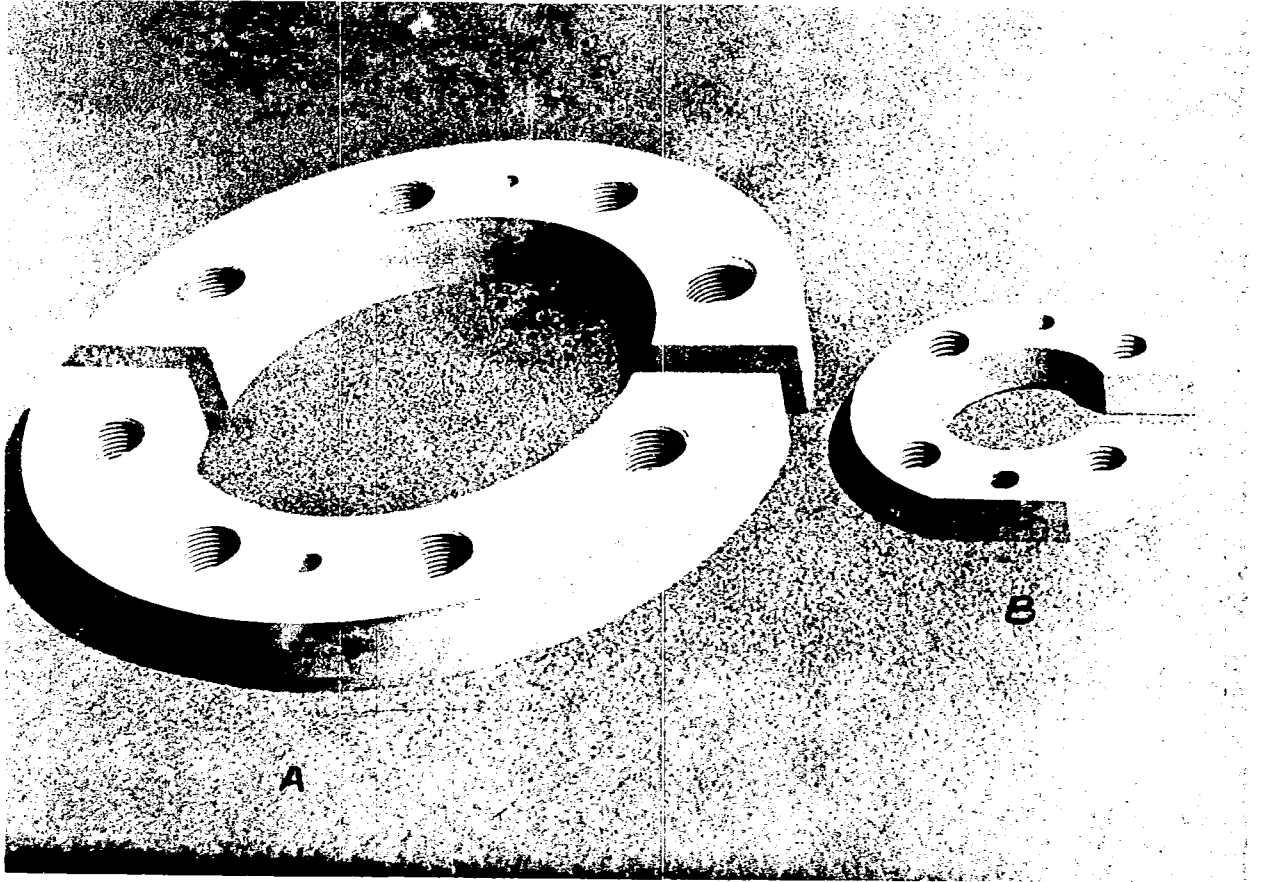

Figure 4-8. Nut Rings



The MSTs should be grouped three abreast if possible. One MST will provide access for in-head lighting. An in-head light is lowered through the MST until it exits the CRDM nozzle inside the head, where it will be secured to the top of the MST. The center MST will contain the camera manipulator and camera for either in-head or fuel assembly inspection. The third MST is provided for an auxiliary camera that can be used for additional in-head viewing or to monitor the movements of the manipulator arm and underwater camera and light above the plenum.

All MST components are constructed of aluminum. Two 8.5-foot-long, 2.75-inch tubes make up the long shaft that allows all operations to be performed from the service structure platform. The two tubes are connected with a coupling (Figure 4-9). The lower tube includes a welded 1.5-inch-diameter flange to support the tube on the CRDM nozzle. Eight holes are available to accommodate the holddown bolts. The lower tube protrudes approximately 1 inch through the flange to provide alignment during placement. Bail supports and a 0.1875-inch-diameter stainless steel bail are also provided for lifting.

4.1.3. Closures

The closures provide radiological seals for use after penetration of the RV. They are separated into two groups: temporary and permanent penetration closures.

Temporary penetration closures are expandable plugs that form a temporary seal at the top of the MSTs and at the openings in the thermocouple nozzles. These plugs will prevent gases and particulates from escaping and prevent tools and other items from being dropped into the RV. They are not intended as a pressure boundary.

The temporary penetration closures are shown in Figure 4-10. These plugs are turn-tite closures. Two sizes are supplied - a 2.75-inch-OD rubber bladder with flange and a 0.625-inch-OD rubber bladder with flange. The plugs are tightened with T-handles. Both types have been modified to prevent disassembly of the unit.

The permanent closures are used to seal the RV after the inspection is complete. Two sizes are required to seal the CRDM and thermocouple nozzles (see Figure 4-11). The larger flange is the CRDM blind flange and covers the CRDM nozzle. It is 2.75 inches thick and 11.5 inches in diameter. The smaller

Figure 4-9. Manipulator Support Tube Coupling



Figure 4-10. Closures

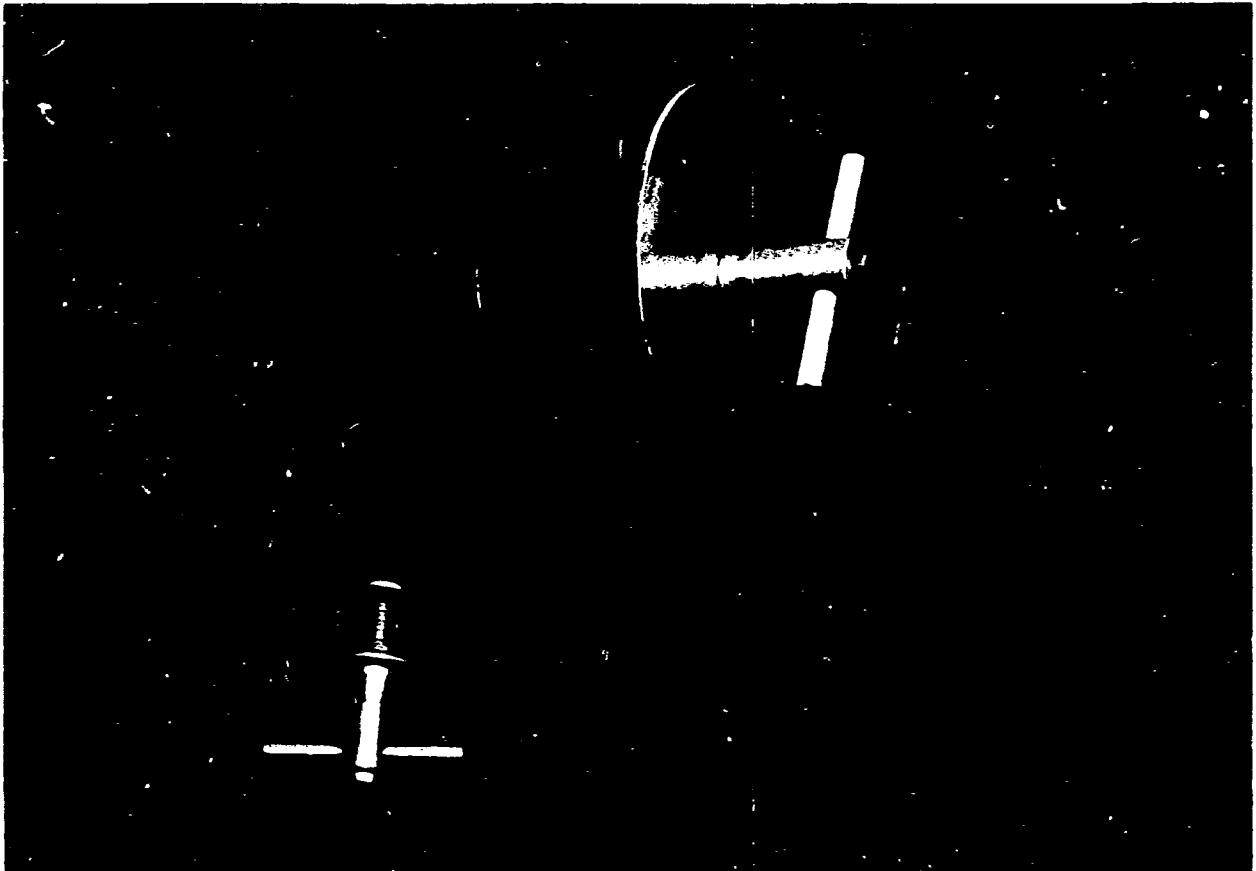
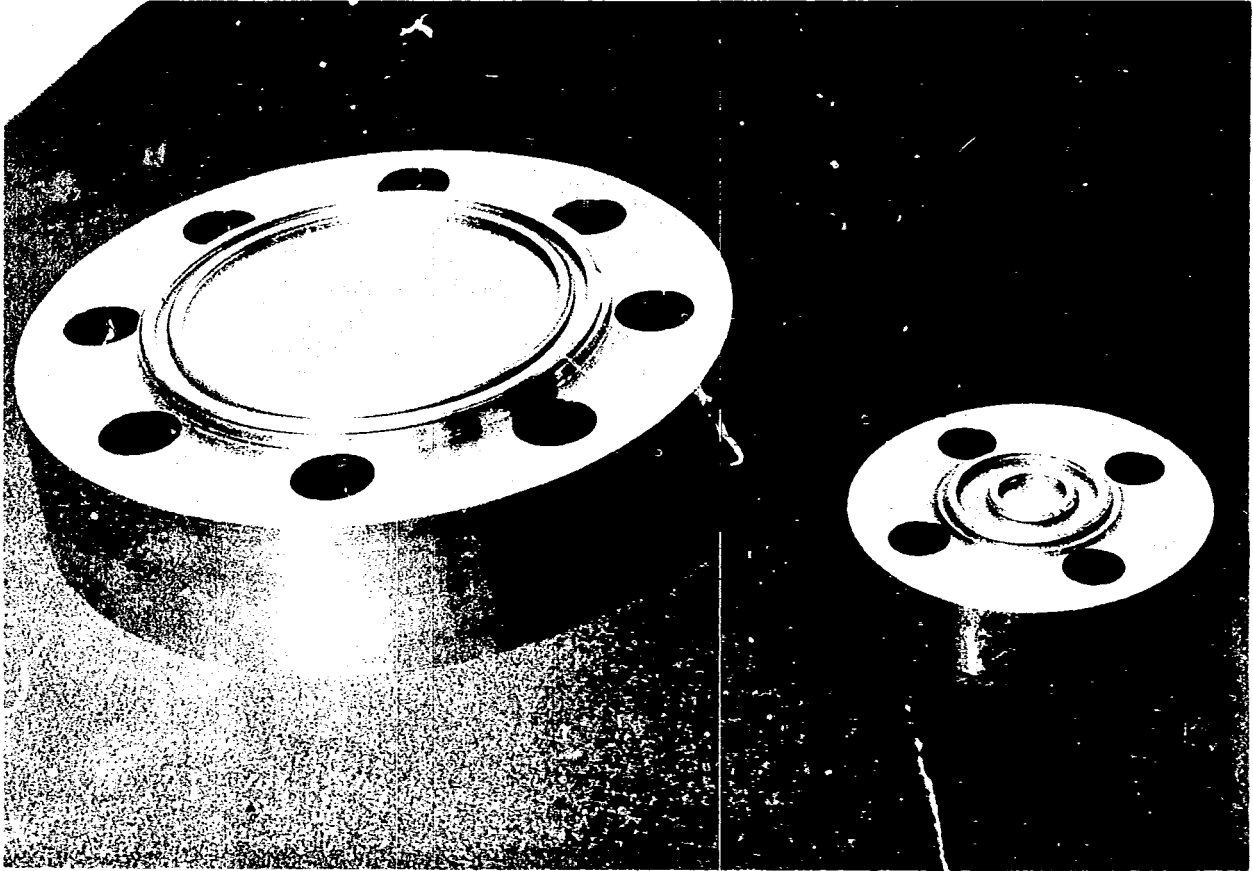

Figure 4-11. CRDM and Thermocouple Nozzle
Blind Flanges



thermocouple blind flange covers the thermocouple nozzle; it is 1.5 inches thick and 5.5 inches in diameter. Both flanges are constructed of type 304 stainless steel and are supplied with two spiral-wound, metallic-asbestos-type gaskets each. The gaskets are shown positioned on the flanges in Figure 4-11.

The CRDM blind flange is secured with eight stainless steel, 1.375-inch hex-head bolts screwed into the nut ring. The thermocouple blind flange is secured with four stainless steel hex-head bolts screwed into the thermocouple nut ring. These flanges can withstand 2300 psi internal vessel pressure, being limited by the strength of the holddown bolts.

4.1.4. Water Level Sensing Equipment

A system is provided to physically measure and provide local and immediate readouts of the RV water level. Water level monitoring during inspection and manipulator operations, especially when CRDMs are removed, is considered essential. This system does not control actual vessel water level. It is a passive system that provides visual and audible alarms to the inspection team if the water level in the reactor exceeds preset high or low limits. The system also provides an electrical output for remote monitoring, which correspond to reactor water level, for remote monitoring.

The water level sensing system is mounted on a 4-foot-square metal panel as shown in Figure 4-13. The panel includes connections for a flexible line leading to a "bubble pipe" sensor and a source of 10 to 20 psig clean air or nitrogen (see the block diagram, Figure 4-12).

System operation is based on the principle of sensing pressure of a gas flowing at a constant rate through a vertical pipe with an orifice at the bottom. Variation in pressure is equivalent to the varying water level on the pipe (i.e., inside the closure head) as the gas "bubbles" to the surface.

A constant differential relay mounted on the panel varies the area of an orifice according to the pressure differential between the source pressure and the pressure applied to the "bubble" pipe as required to maintain a constant flow. Gas flow is indicated by a rotometer included with the system. The water level gage, differential pressure transmitter, audible alarm, and alarm light switch all sense the "bubble pipe" pressure, which is compared to atmospheric pressure within each device. This differential is translated to water level as a electrical output or an alarm. Both alarms include a means of

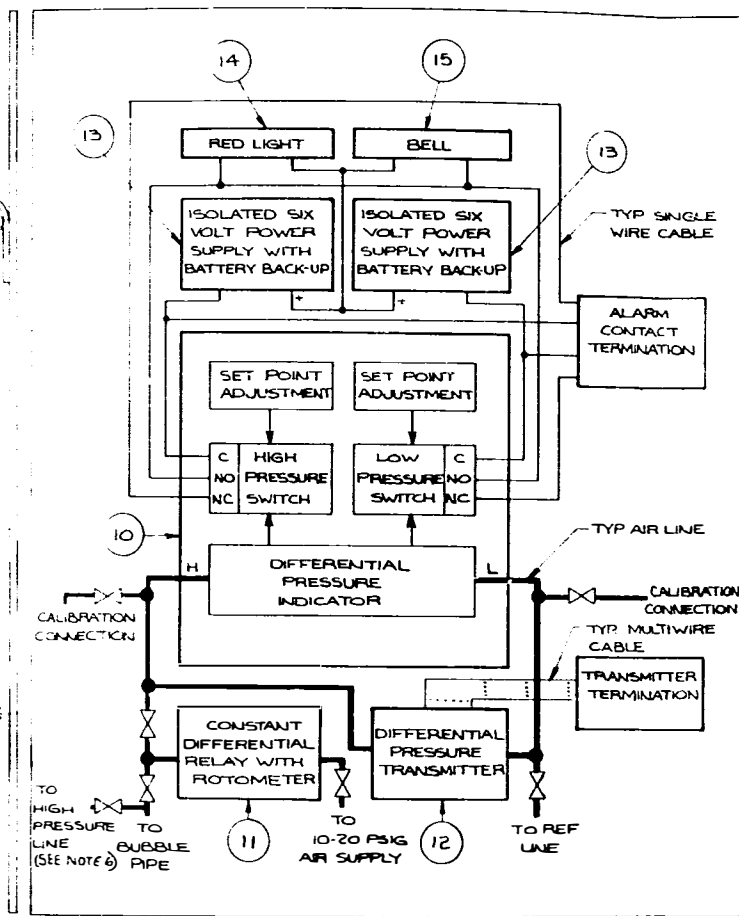
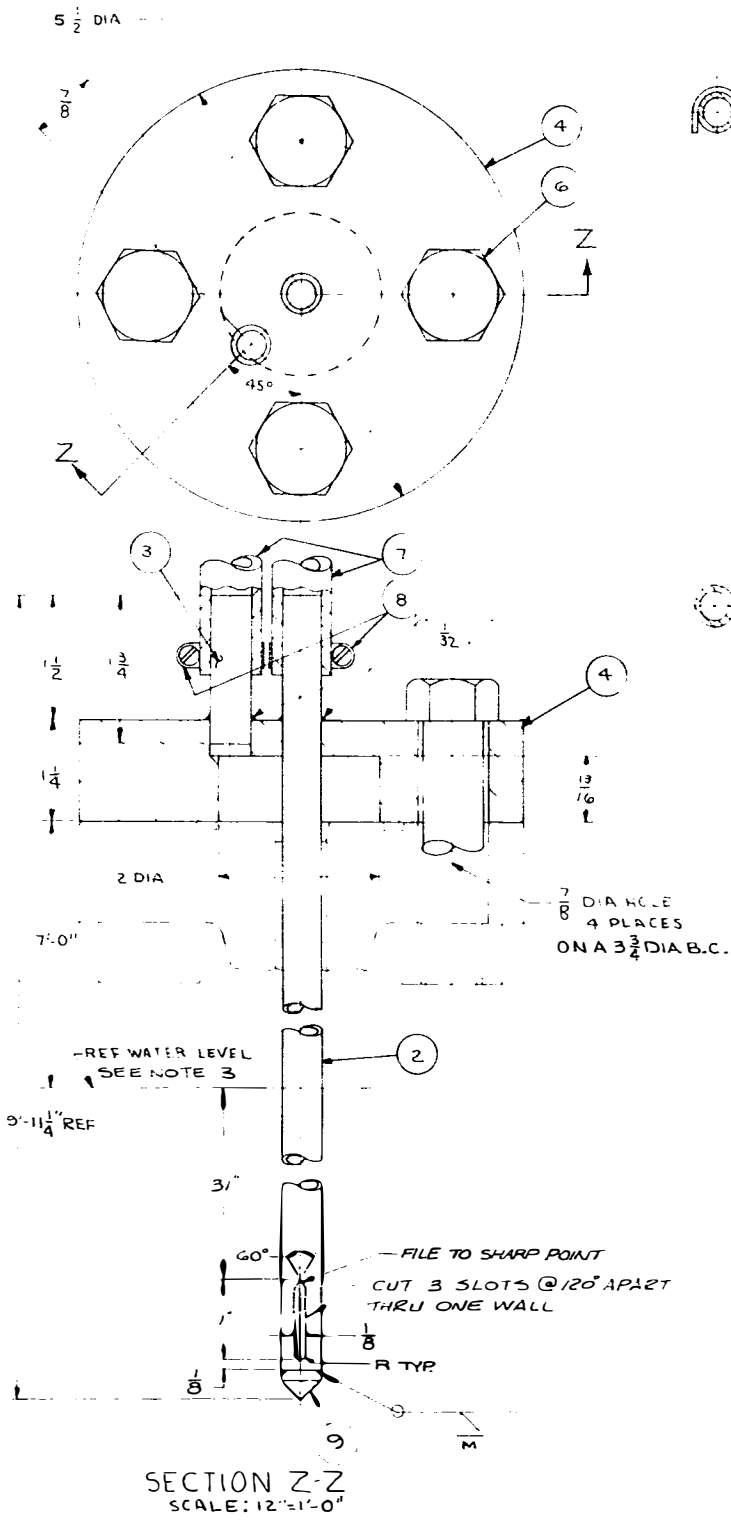

BLOCK DIAGRAM
SEE NOTE 1
SCALE: NONE

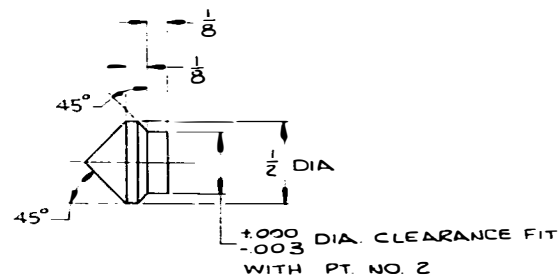

9 END CAP
SCALE: 2x

Figure 4-12. Water System

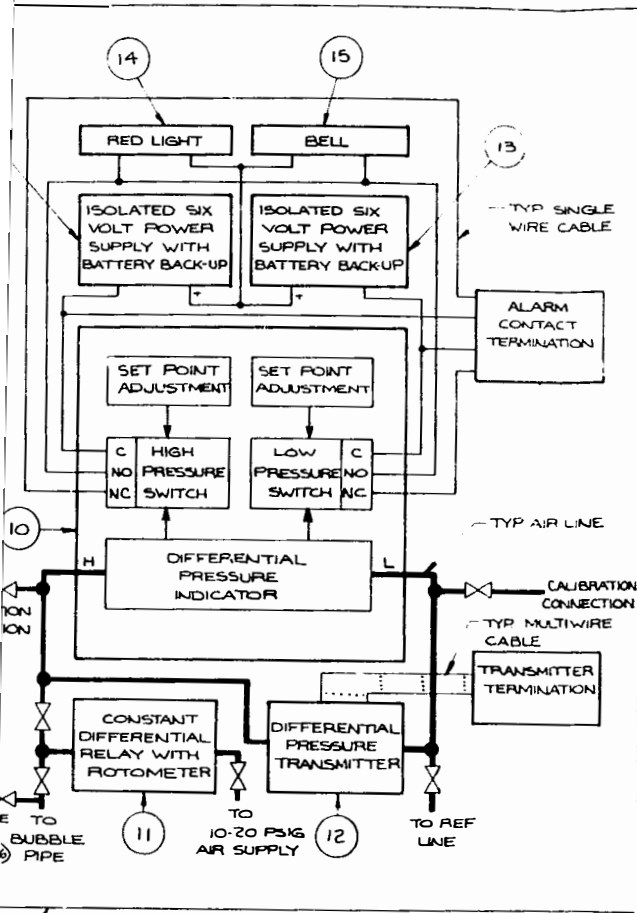

5 BLOCK DIAGRAM
SEE NOTE 1
SCALE: NONE

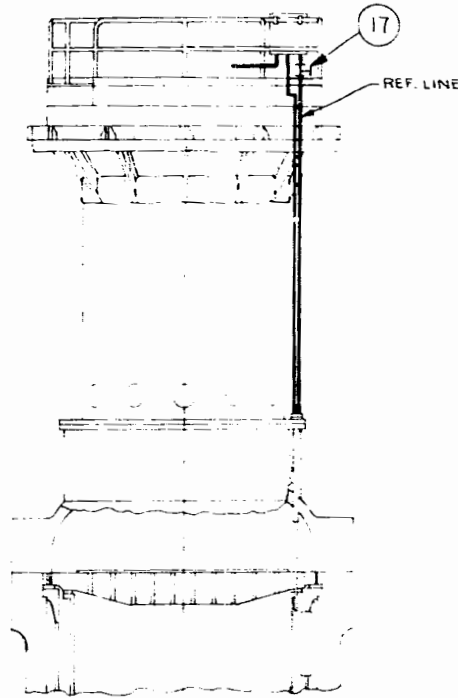

INSTALLATION SCHEMATIC
SCALE: NONE

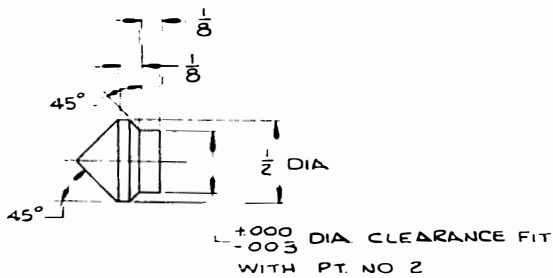

9 END CAP
SCALE: 2X

BILL OF MATERIAL		DESCRIP
1	1	1121396D PRIMARY WATER LE
2	1	1121396D BUBBLE PIPE, 1/2 ODN
3	1	1121396D REF. LINE, 1/2 ODX
4	1	1121396D FLANGE
5	1	1128412F PANEL ASSEM
6	4	1121396D HEX HD. BOLT, 3/4-10
7	35	1121396D 1/2 I.D. TYGON T
8	2	1121396D HOSE CLAMP
9	1	1121396D END CAP
10	1	1121396D DIFFERENTIAL PRES
11	1	1121396D WITH HIGH & LOW
12	1	1121396D CONSTANT DIFFER
13	2	1121396D WITH ROTOMETER
14	1	1121396D DIFFERENTIAL P
15	1	1121396D TRANSMITTER IC
16	1	1121396D ISOLATED SIX VOLT
17	1	1121396D SUPPLY WITH BA
		1121396D RED LIGHT -
		1121396D ALARM BELL
		1127718C SCHEMATIC D
		1121396D 1/2 O.D. TEE

NOTES

1. FOR PARTS SPECIFICATION, SEE DOCUMENT
2. TORQUE BOLTS TO 8-12 FT. LBS
3. REFERENCE WATER LEVEL IS 1 (ONE) FT
4. ALL INTERCONNECTING WIRES TO BE IN CABLE DUCT.
5. SEE DWG 1128412F FOR PANEL ASSEMBLY AND MODEL NO.
6. WITH VALVE #4 CLOSED CHECK VALVE LINE TO 20 TO 50 PSI SUPPLY TO PREVENT OBSTRUCTION IN BUBBLE PIPE

Figure 4-12. Water Level Sensing System

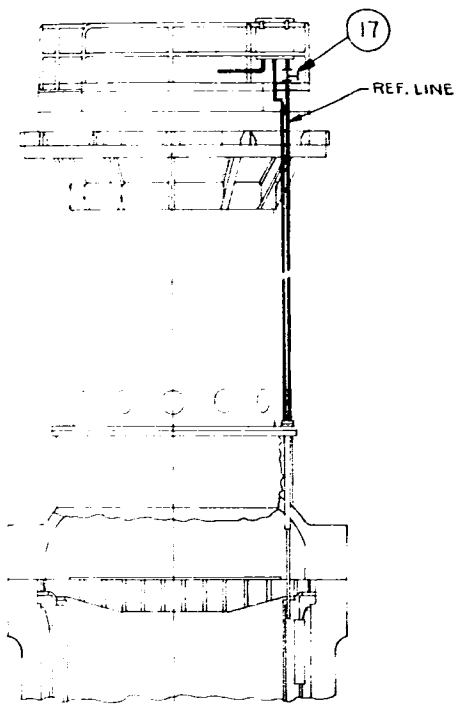
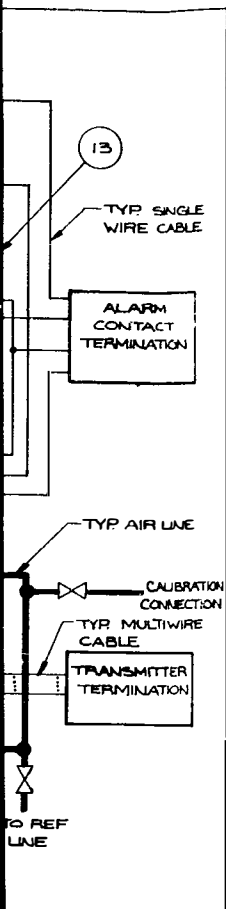

INSTALLATION SCHEMATIC
SCALE: NONE

BILL OF MATERIAL				
PART NO.	QUAN.	DWG NO.	DESCRIPTION	MAT'L SPEC.
1	1	1121396D	PRIMARY WATERLEVELSENSING SYS.	
2	1	1121396D	BUBBLE PIPE, 1/2 O.D. x 3/8 LG TUBING	316L SST
3	1	1121396D	REF. LINE, 1/2 O.D. x 3/8 ID TUBING	316L SST
4	1	1121396D	FLANGE	SST
5	1	1123412F	PANEL ASSEMBLY	
6	4	1121396D	HEX HD. BOLT, 3/4-10UNC-2A x 3 1/4 LG.	STEEL
7	35 FT.	1121396D	1/2 I.D. TYGON TUBING (1/8 MIN. WALL THK.)	
8	2	1121396D	HOSE CLAMP	SST
9	1	1121396D	END CAP	316L SST
10	1	1121396D	DIFFERENTIAL PRESSURE INDICATOR WITH HIGH & LOW PRESSURE SWITCHES	SEE NOTE 5
11	1	1121396D	CONSTANT DIFFERENTIAL RELAY WITH PHOTO-METER	SEE NOTE 5
12	1	1121396D	DIFFERENTIAL PRESSURE TRANSMITTER 10-50MA RANGE	SEE NOTE 5
13	2	1121396D	ISOLATED SIX VOLT POWER SUPPLY WITH BATTERY BACK-UP	SEE NOTE 5
14	1	1121396D	RED LIGHT - SIX VOLTS	SEE NOTE 5
15	1	1121396D	ALARM BELL	SEE NOTE 5
16	1	1127718C	SCHEMATIC DIAG.	
17	1	1121396D	1/2 OD TEE	SST

NOTES

- FOR PARTS SPECIFICATION, SEE DOCUMENT NO. 86-1123484.
- TORQUE BOLTS TO 8-12 FT. LBS.
- REFERENCE WATER LEVEL IS 1 (ONE) FT ABOVE PLENUM COVER.
- ALL INTERCONNECTING WIRES TO BE ROUTED THROUGH CABLE DUCT.
- SEE DWG 1128412F FOR EQUIPMENT MANUFACT. AND MODEL NO.
- WITH VALVE #4 CLOSED CONNECT HIGH PRESSURE LINE TO 20 TO 50 PSI SUPPLY FOR CLEARING ANY OBSTRUCTION IN BUBBLE PIPE IF REQ'D.

CLEARANCE FIT
NO. 2

Figure 4-13. Water Level "Bubble Pipe"
Indication System

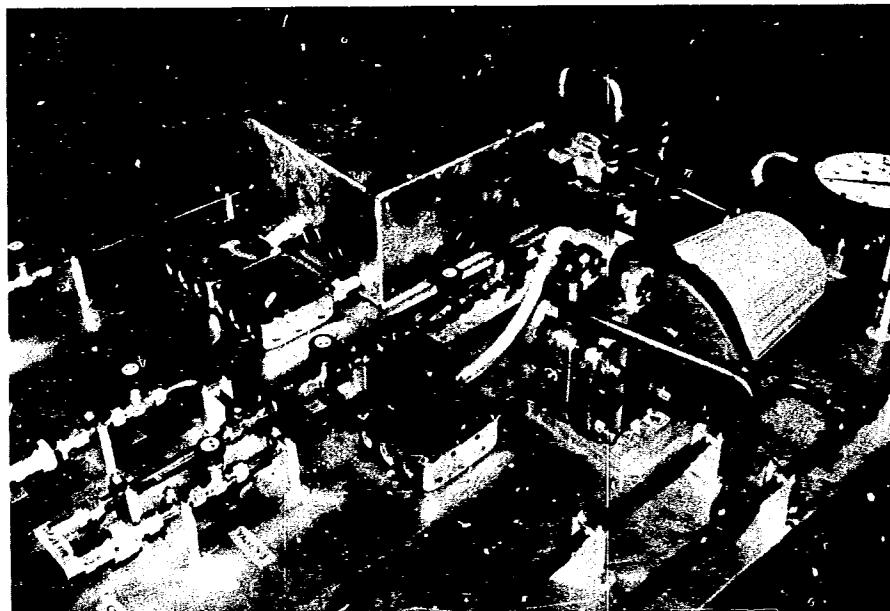
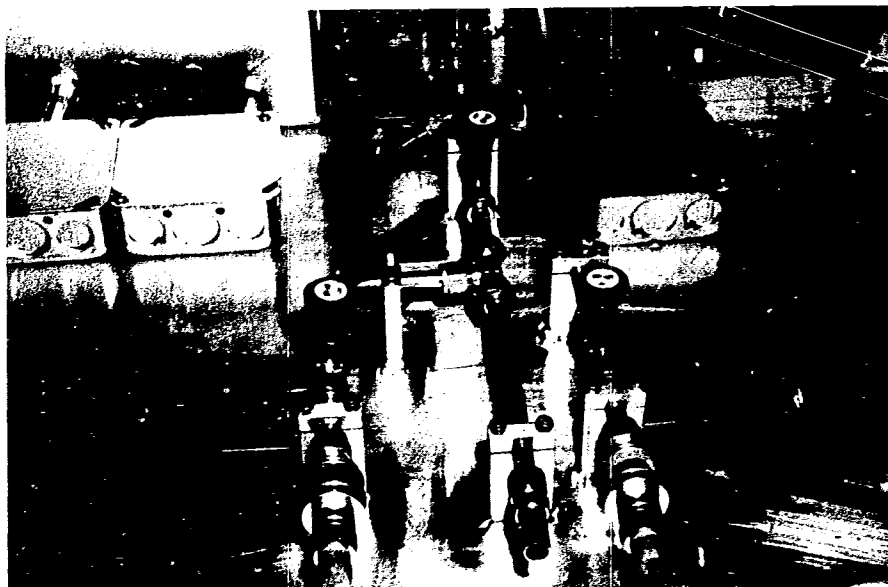

adjustment so that preset values of pressures (i.e., levels) can be set to yield alarms at high or low level points.

4.2. Control Rod Drive Mechanism Removal Tools

Standard tooling for leadscrew uncoupling and CRDM removal may not be adequate due to conditions experienced during the accident. Possible adverse conditions include corrosion of bolts and fittings, melting or fusing of the leadscrew to the control rod spider, warpage of leadscrews due to thermal stresses, and melting or warpage of the guide tube brazements.

Contingency tools have been built to permit CRDM removal in case problems develop. These include a CRDM holddown bolt removal tool, a stator removal tool, and plasma-arc cutter systems for in-head and ex-head cutting of leadscrews.

4.2.1. Bolt Removal Tool

The bolt removal tool will supplement the standard techniques for removing the CRDM holddown bolts. A torque of 2500 ft-lb can be developed with this tool. This is a conservative estimate of the torque necessary to smear the threads and remove the holddown bolts. The tool also has the capability to capture the holddown bolt in the tool socket.

The bolt removal tool, shown in Figures 4-14 through 4-17, comprises three basic parts: (1) the bolt tool, (2) the tool plate, and (3) the torque multiplier assembly.

The bolt tool body is constructed from a pair of 2-inch-OD \times 0.25-inch wall, type 4130 steel tubes. The two tubes are connected with a positive action coupling of type 4340 steel. A 1.375-inch, single hex-head socket is welded to the bottom of the lower tube for engagement of the bolt.

A 1-inch-square drive female socket is welded to the top of the upper tube for torque multiplier engagement. An internal device that spans the entire length of the tool operates the capturing mechanism. This device consists of an aluminum rod, operated from the top of the tool, with a single-acting, positive pin-lock connected at the bottom. This locking mechanism protrudes through the hex socket and engages in the axial hole in the holddown bolt. The tool also has a 0.1875-inch-diameter stainless steel bail for lifting it through the tool plate.

Figure 4-14. Bolt Removal Tool and Tool Plate

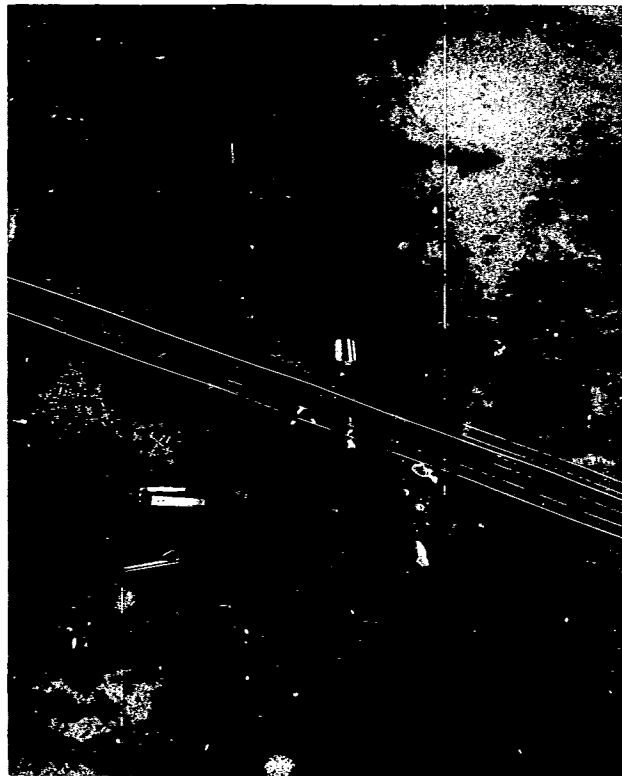
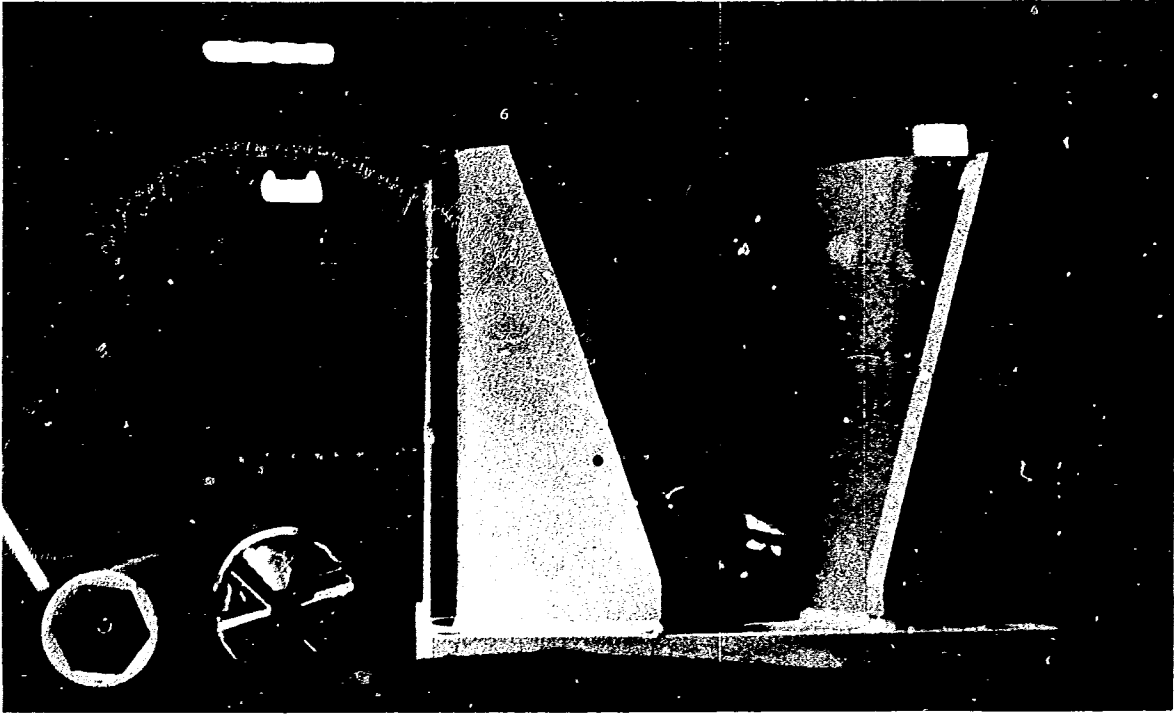

Figure 4-15. Bolt Removal Tool Accessories

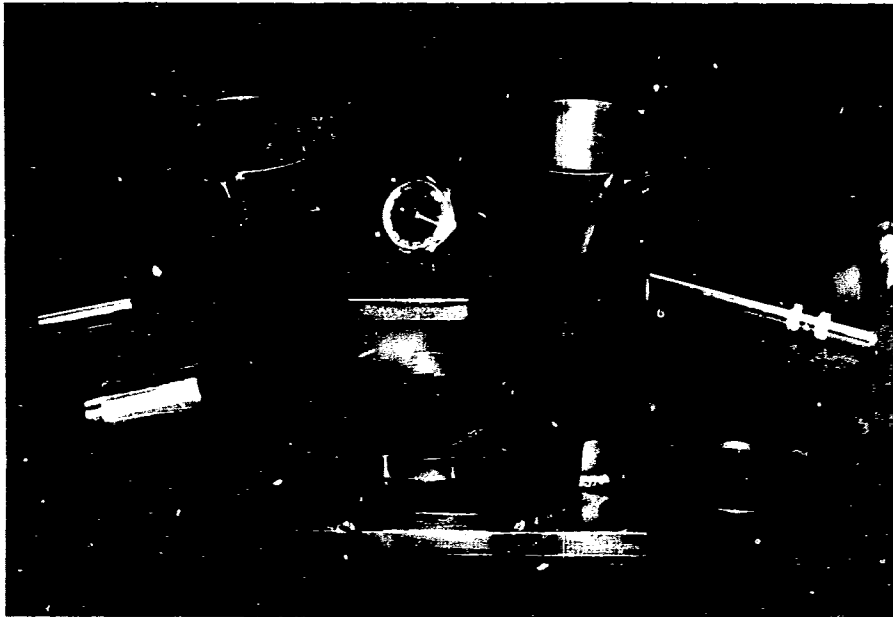
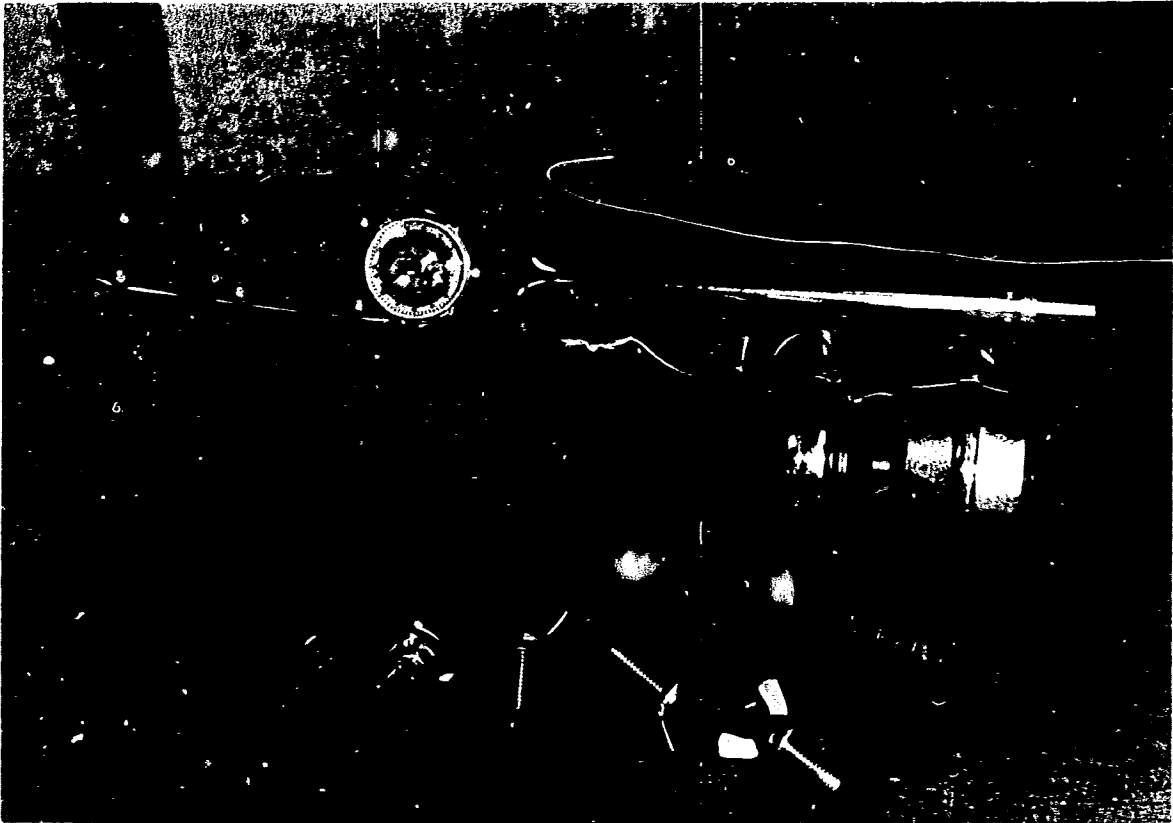

Figure 4-16a. Torque Multipliers and Tool Plate

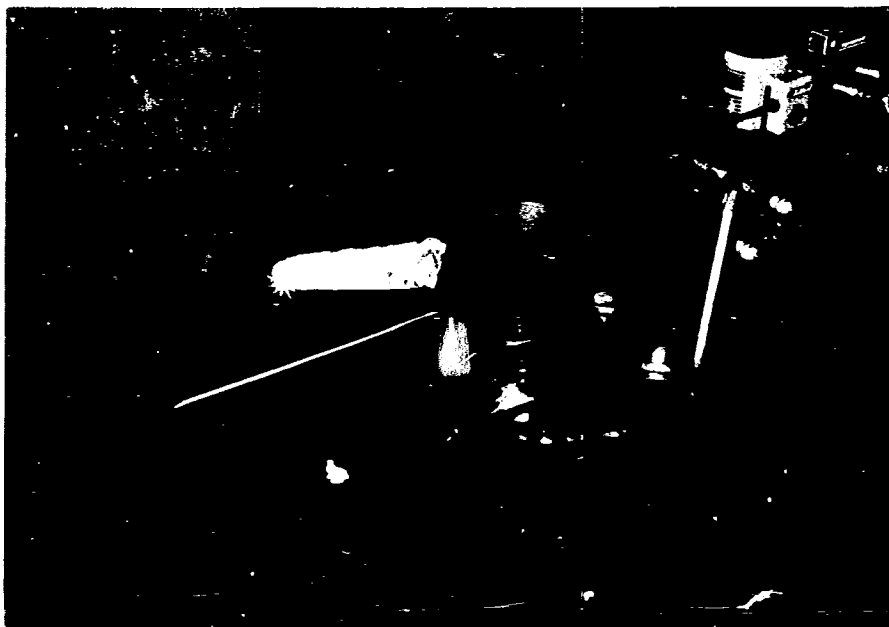

Figure 4-16b. Tool Plate and Torque Multipliers During Mockup Testing

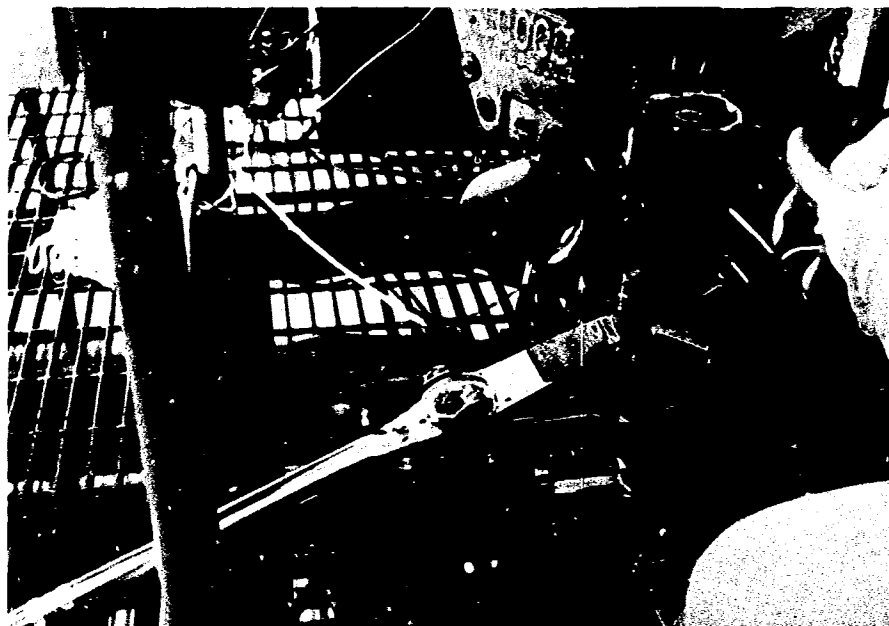
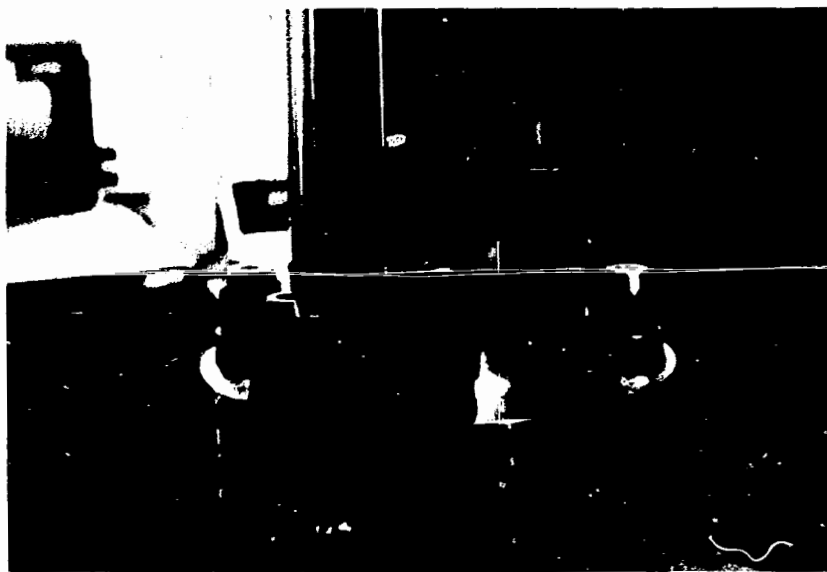

Figure 4-17. Lower End of Bolt Removal Tool



The tool plate assembly consists of three sections: (1) the plate, (2) the sleeves and gussets, and (3) the spacer and lanyard. The plate is made of type 1025 steel, 0.75 inch thick and 12 inches square. A 4.25-inch-diameter hole is located at the center of the plate to permit clearance for the CRDM. Two 3-inch-diameter holes are provided for bolt tool access through the plate. These holes are positioned so that three rotations (four orientations) of the plate will provide the necessary positioning to detorque all eight bolts. Four 1-inch-diameter holes in each corner of the plate are used to secure the tool plate to the service structure with four specially modified wing nuts. Also, two areas have been machined to make the tool plate lighter and easier to maneuver. The gussets and semi-cylindrical sleeves provide the necessary bearing support for the torque multipliers. The gussets are made of type 1025 steel, and the sleeves are 1026 steel. These parts are positioned around the bolt tool access holes and are welded to the tool plate and each other to become single units. The spacer (a washer with 1.5 inch OD, 0.53 inch ID and 0.5 inch thick) for the torque multipliers is connected to a gusset by a lanyard to reduce the number of loose parts.

The torque multipliers provide a mechanical advantage of approximately ten. The assembly consists of several parts, including large and small torque multipliers, and anti-backlash ratchet, a torque wrench, 10- and 20-inch extensions, and various adapters to connect these units (see Figure 4-15). The torque wrench is a snap-on device with a range capacity of 250 ft-lb, incremented in 5 ft-lb values. It features accuracy to within 2% of dial capacity, a follow pointer to mark the maximum torque obtained, and a 0.75-inch square drive. The large and small torque multipliers are also snap-on models. The small torque multiplier has a rated capacity of 1000 ft-lb and a mechanical ratio of 4:1. It incorporates 0.5-inch female and 0.75-inch male square drives. The large torque multiplier has a mechanical ratio of 4:1 and a 2000 ft-lb rated capacity. Drive capability is through the 0.75-inch female and 1-inch male square drives. The anti-backlash ratchet maintains the torque of the torque multipliers while preventing backlash. This ratchet requires a special square drive adapter to be added to the assembly. A locking ring holds the adapter and ratchet together.

The ratchet adapter has 0.5-inch male and female square drives to accommodate the torque wrench and small torque multiplier. The small and large torque

multipliers are connected via the 0.75-inch square drive sockets. The large torque multipliers' 1-inch square male drive then sets inside the 1-inch square female drive of the bolt tool for final torque transmittal to the bolt tool. The torque multiplier assembly sections, including the large and small torque multipliers and anti-backlash ratchet, are finally connected with lanyards, in series, to reduce the number of loose parts.

Extensions of 10 and 20 inches are supplied to allow the torque wrench clearance above adjacent CRDMs. The longer extension is a 0.5- to 1-inch drive adapter extension used after the bolts have been detorqued and the torque multipliers removed for quick unfastening of the holddown bolts. The short extension is a 0.5-inch drive extension used in conjunction with the torque multipliers (see Figure 4-16).

4.2.2. Stator Removal Tool

The stator removal tool is a contingency tool that should be used if the stator is stuck and the normal stator tool does not prove adequate. The basic function of the stator removal tool is to lift the stators off the CRDMs.

The tool consists of upper and intermediate plates and a yoke at the bottom. Four 0.1875-inch-diameter stainless steel cables connect the three plates at the corners. The elevation of the intermediate plate is adjusted by four T-handled cable clamps that produce a bearing thrust on each of the four cables. The intermediate plate has an eyebolt for lifting purposes and a sleeve to secure the top of the stator while lifting. The tool is vertically supported by a triple-leg chain connected to three eyebolts located on the upper plate (see Figures 4-18 and 4-19). Lifting force is monitored by a 2000-lb Dillon dynamometer.

The 0.1875-inch-diameter stainless steel cables are fixed to the upper plate and yoke by safeline wire rope clips. The yoke is constructed of 304 stainless steel, while the upper and intermediate plates are carbon steel. The triple-leg chain is a linked chain assembly connected to the upper plate by three 0.5625-inch stainless steel eyebolts joined by a universal link at the top.

The yoke is used to develop the initial lifting force needed to break the stator free. It is lowered between adjacent CRDMs until it can be maneuvered into position under the stator housing. A lifting force is then applied via a crane until the stator breaks free. The maximum lifting force is 1500 pounds.

Figure 4-18. Stator Removal Tool

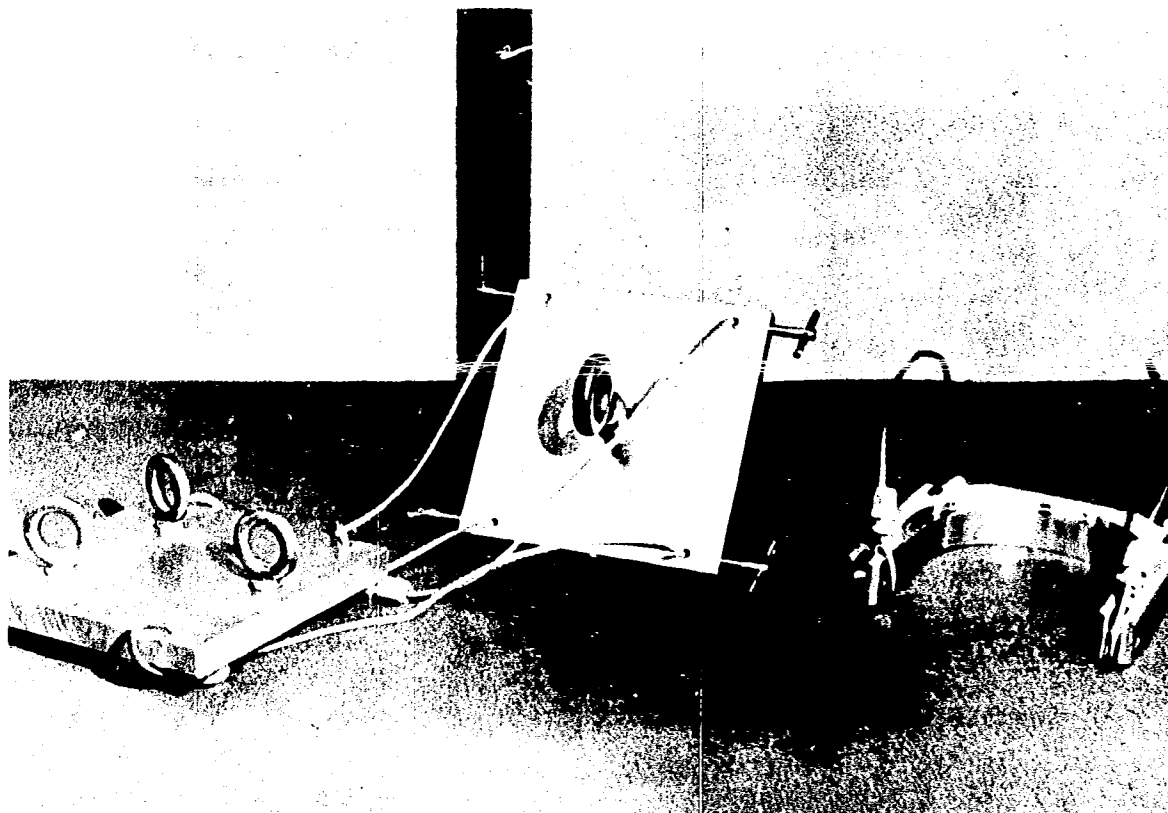

Figure 4-19. Mockup Operation of Stator Removal Tool



The intermediate plate is then positioned on top of the CRDM with its sleeve covering the upper part of the CRDM. It is secured via the four T-handled cable clamps.* The lifting force is then reduced to zero, after which the crane is disconnected from the triple-leg chain and connected to the eyebolt on the intermediate plate. The stator is then raised above the CRDM and taken to storage.

4.2.3. Ex-Head Plasma-Arc Cutting

The ex-head (external to closure head) plasma-arc tooling and operating techniques were developed to provide a contingency method of removing a CRDM. Such contingency methods may be necessary if all CRDMs are damaged or inoperative and thus preclude normal uncoupling of leadscrews and normal CRDM removal.

The method requires cutting a 3- by 6-ft hole in the outside shell of the service structure to gain access to the peripheral CRDM at the flange level. The leadscrews are exposed by separating the CRDM housing from its mating flange on the closure head CRDM nozzles by utilizing clearances available inside the mechanism. Cutting or lowering the leadscrew support tube at this location permits the leadscrew to be exposed and cut, and the CRDM can be removed.

Tool and Procedure Description

Tools designed for ex-head leadscrew cutting include (1) the basic plasma-arc cutting torch, (2) various clamps for holding the leadscrew support tube and leadscrew, and (3) a centering and lifting tool that threads on the cut leadscrew and permits the lower portion of the leadscrew to be lowered 2 feet. This tool also centers the cut leadscrew to enable a "push-pull" tool to be lowered over it before it is removed.

The "push-pull" tool is used to shear the pins between the lower end of the leadscrew and the bayonet end fitting, which latches a control rod. After shearing these pins, removal of the "push-pull" tool also removes the lower portion of the cut leadscrew. Removal of this leadscrew segment provides an

- - - - -

*If the position indicator is not removed, this step is omitted and the stator is secured by a retaining belt wrapped around the four cables and the water jacket. All lifting is done via the upper plate in this configuration.

access path to the reactor interior for camera inspection and in-head cutting of leadscrews.

After separating the CRDM and nozzle flanges, the leadscrew support time clamp is installed. (See Figures 4-20 and 4-21 for leadscrew support tube clamp and flange separation.) The nut holding the support tube can then be removed and the tube lowered until the clamp rests on the nozzle flange. If the nut is damaged or locked, the tube can be cut using a hand-held plasma-arc cutting torch with the clamp in place. Either method exposes the leadscrew for cutting.

A leadscrew clamp (shown in Figure 4-21) is inserted on the screw thread with a clamp manipulator and "run down" to the support tube clamp before cutting the leadscrew. This action prevents downward movement of the leadscrew after it has been cut.

A leadscrew cutting guide fastens to the cutting end of the torch was developed to aid in making a smooth horizontal cut in addition to providing proper spacing of the torch from the leadscrew. An accurate, clean cut is important since the centering and lifting tool (shown in Figure 4-22) is threaded on the leadscrew after the cut.

After the leadscrew has been cut and the CRDM has been removed with a crane, the exposed end of the leadscrew is deburred using hand tools and the centering and lifting tool is threaded on. By raising this tool and the leadscrew slightly, the leadscrew clamp can be removed. Then the support tube and its clamp can be raised and removed from the leadscrew. The leadscrew clamp can now be removed and the leadscrew and coupled control rod lowered until they stop or rest on the fuel assembly.

After successfully lowering the leadscrew, the lower section of the push-pull tool (see Figure 4-23) can be lowered over the centering and lifting tool. The bottom end of the push-pull tool will then rest on the control rod spider assembly. (Note: The end fitting of the push-pull tool is 1.625-inch ID the lower end of the leadscrew is 1.500 inch or 0.0625 inch radial clearance between tool ID and leadscrew. If a control rod guide tube brazement is melted, the maximum offset possible to ensure proper alignment of the tool on the leadscrew is 0.0625 inch.) After removing the centering and lifting tool, the top portion of the push-pull tool is lowered and attached to the lower section. The top section of the push-pull tool contains a split nut with a spreader bar

Figure 4-20. Leadscrew Support Tube Clamp

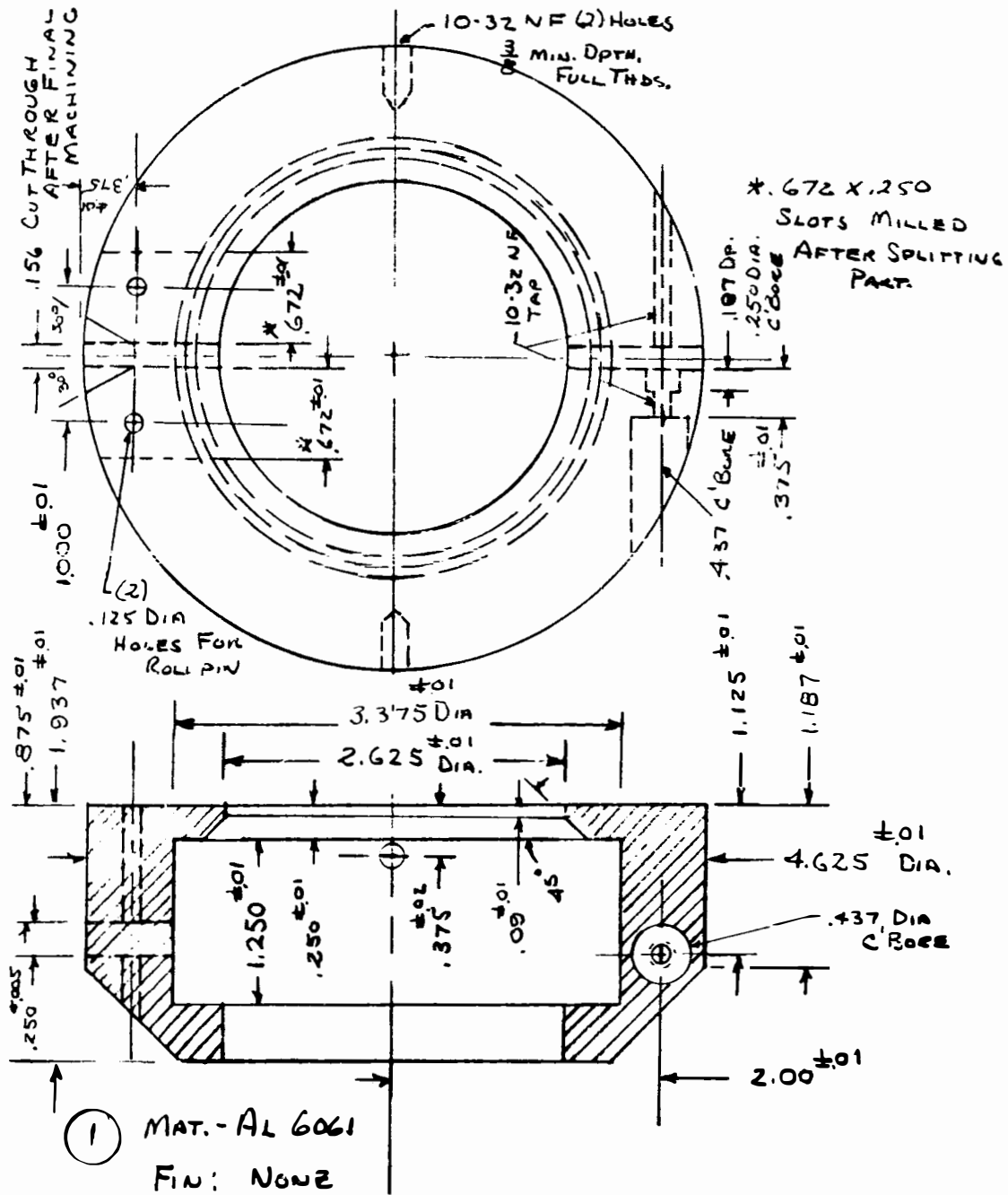
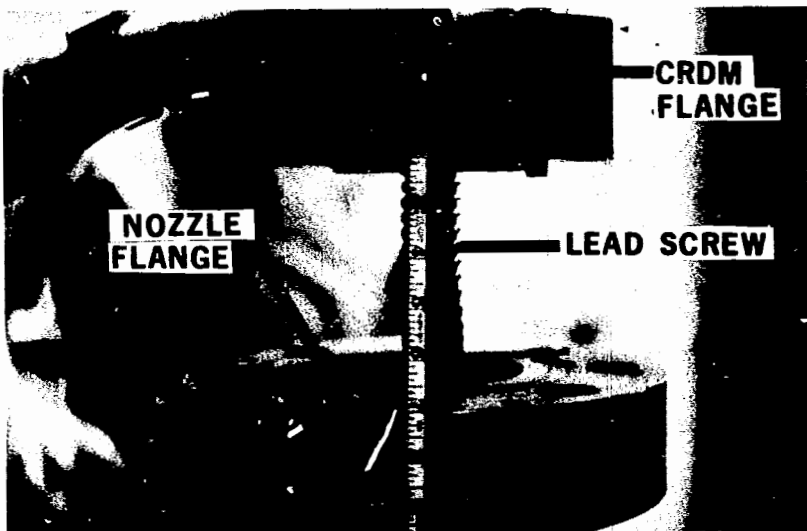

Figure 4-21. Leadscrew Clamp



LEADSCREW CLAMP



FLANGE
SEPARATION

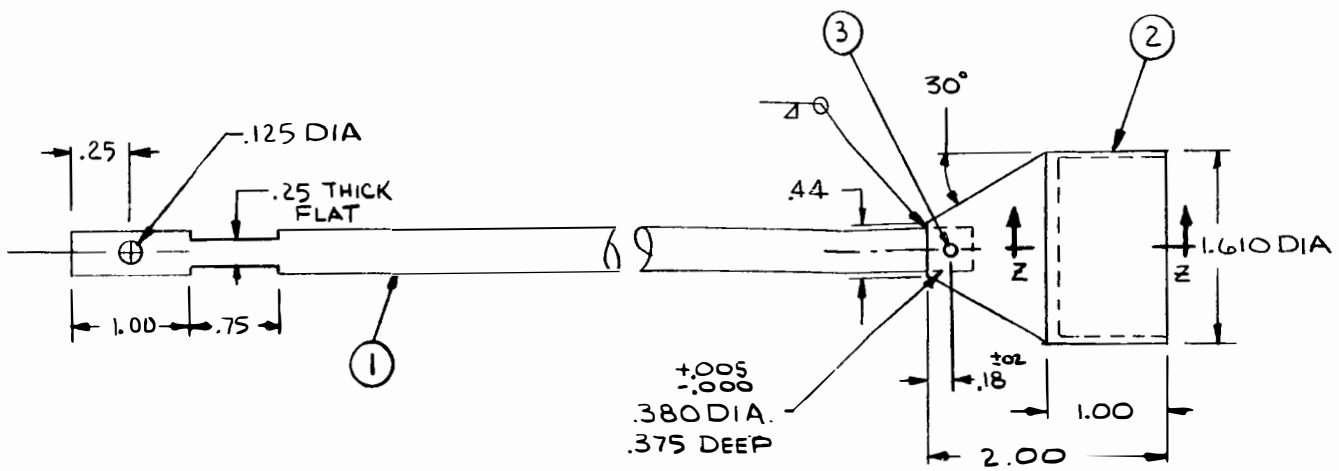

PART NO.	QUAN	QWG.
1	1	11268
2	1	11268
* 3	1	

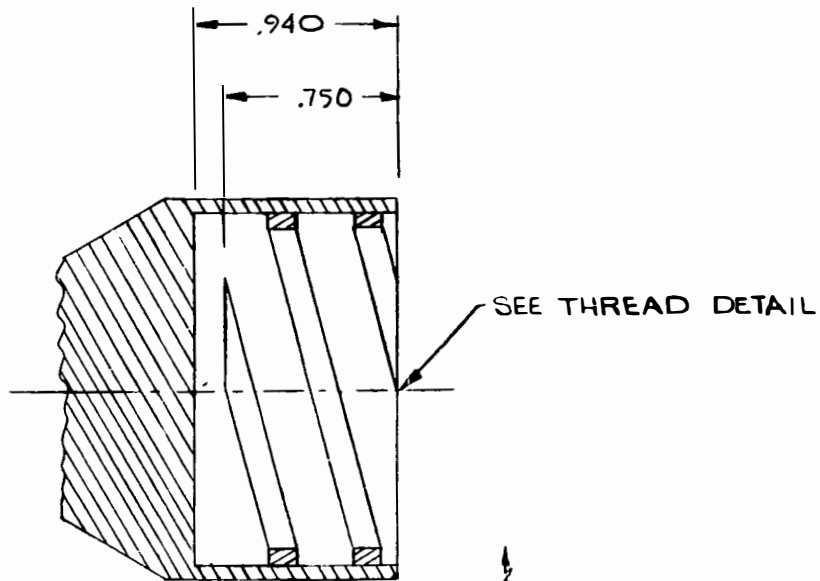

* DRILL THE AFTER WELL BE SHORT

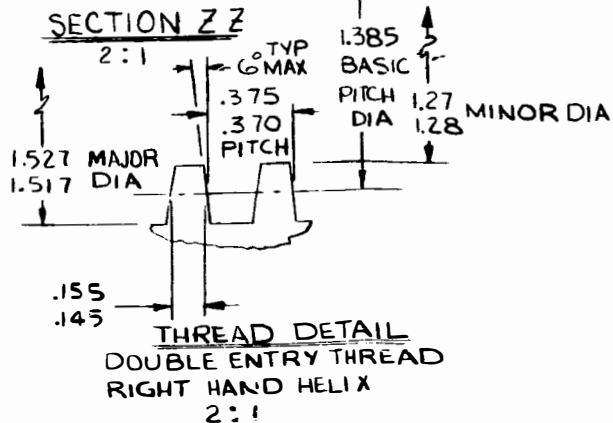
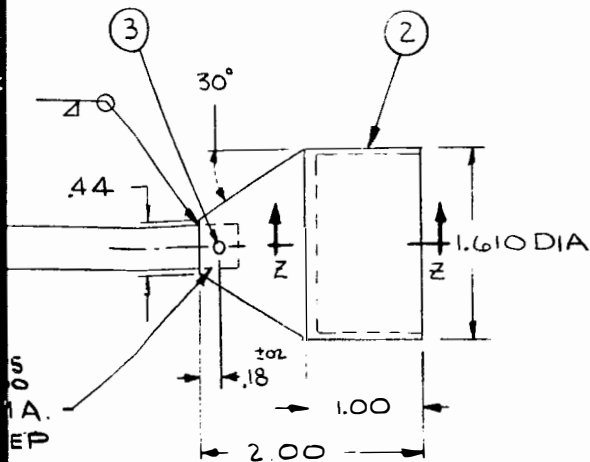

Figure 4-22. Leadscrew Centering Lifting Tool



BILL OF MATERIAL				
PART NO	QUAN	BWG NO	DESCRIPTION	MAT'L SPEC
1	1	1126889 P1	.375 DIA X 30.00" LONG	AL 6061 T6
2	1	1126889 P2	CONE	AL 6061 T6
* 3	1		1/8 DIA ROLL PIN	STEEL

* DRILL THRU AND INSTALL 1/8 DIA ROLL PIN AFTER WELDING CONE TO SHAFT. PIN SHOULD BE SHORT ENOUGH NOT TO PROTRUDE THRU CONE.

SEE THREAD DETAIL

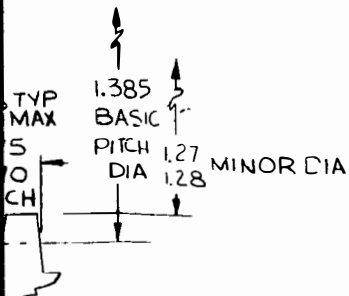

SEE DETAIL
TRY THREAD
D HELIX

Figure 4-23. Push-Pull Tool and Accessories



Note: Used for shearing attachment pins between leadscrew and bayonet end fitting that attach to the control rod.

that fits around the leadscrew. When the top section of the tool is installed, pushing on the spreader bar collapses the split nut around the leadscrew. A sleeve is then installed around the split nut to hold it firmly against the leadscrew.

A flange at the top of the lower section of the push-pull tool serves as a mount for a hydraulic jack which has a hollow center. The jack is lowered around the upper section of the push-pull tool until it rests on the flange. The jack is then bolted to the flange, and a pin is inserted through the jack and the inner member (top section) of the tool.

As the jack is pressurized, the lower section of the tool exerts downward force against the control rod spider assembly and upward force on the leadscrew. This force shears the pins that attach the leadscrew to the bayonet end fitting, which couples the control rod assembly to the leadscrew. After the pins are sheared, the upper part of the leadscrew and the push-pull tool can be removed, providing access to the top of the core.

Pins sheared during mockup testing has hardness ranges of R_C -27-28 and R_C -44. The pins at TMI-2 are expected to have a hardness of R_B -90 with a tensile strength of 100 ksi. The maximum hardness thought possible is R_C -44 with a tensile strength of 160 ksi.

B&W's calculations indicate that the leadscrew assembly would stretch approximately 0.2 inch when subjected to the 25-ton tensile force calculated as the maximum needed to shear the pins. This is equivalent to 400 ft-lb of stored energy. If the break occurred at the upper pinned connection between the leadscrew and lower extension, approximately two-thirds of this energy would be transmitted to the freed upper end. This would result in an upward "jump" of up to 3 feet if unrestricted. The remaining one-third of the energy (approximately 130 ft-lb) will be transmitted as impact energy to the top of the fuel assembly.

Based on mockup testing, restraints must be provided to contain the upper end and thus eliminate the missile potential. The effect of the calculated impact load on the fuel assembly will depend on conditions such as the amount of energy lost through damping, friction, etc. Most significantly, however, the actual condition of the upper end fittings and the fuel assembly itself will determine the effects of any impact load.

4.2.4. In-Head Plasma-Arc Cutting and Leadscrew Clamping

The in-head plasma-arc cutting technique provides another set of contingency tooling in the event that leadscrews cannot be disengaged from the control rods using normal tooling. This technique permits cutting the leadscrews under the RV closure head while operating from the top of the CRDM service structure, minimizing time and man-rem exposure. The technique requires that at least one adjacent CRDM nozzle must first be opened using the normal or ex-head removal techniques described in section 4.2.3. Leadscrew cutting is then accomplished approximately 22 feet below the service structure working platform just above the control rod guide tube brazement (see Figure 4-25). There the leadscrew is exposed for 2.625 inches at an elevation between the bottom of the leadscrew support tube and the top of the control rod guide brazement.

Before cutting a leadscrew, it is necessary to ensure that its lower segment and the attached control rod assembly do not drop further into a distorted fuel assembly. A leadscrew clamp and manipulator were designed to remotely place a clamp on the leadscrew with the clamp resting on top of the control rod guide brazement. With this clamp in place, the severed leadscrew lower section cannot be dropped. The clamp manipulator is removed after the clamp is installed. The plasma-arc cutter and its manipulator are then installed and positioned to cut the leadscrew.

4.2.4.1. Tooling and Procedure Description

Use of the in-head cutter requires access via an open CRDM nozzle, and the manipulator support tube (shown in Figure 4-24) must be bolted to the CRDM flange. The support tube has the same ID as the CRDM nozzle and provides a guide for inserting the in-head tooling.

The leadscrew clamp manipulator is fabricated in three sections. The sections are short enough to permit building access through the personnel hatch. The sections are joined inside the containment using an overlapping, spring-loaded pin joint. Five control cables inside the manipulator tube must be connected before completing the pin joint. Four mechanical and one electrical connection are made. One cable rotates the clamp arm to a 90 degree position with respect to the tool. Two cables are used to radially position the manipulator relative to the adjacent leadscrew. Another cable releases the clamp, and the final cable is an electrical control wire, which indicates proper engagement weight.

Figure 4-24. Manipulator Support Tube



Figure 4-25. Reactor and Service Structure

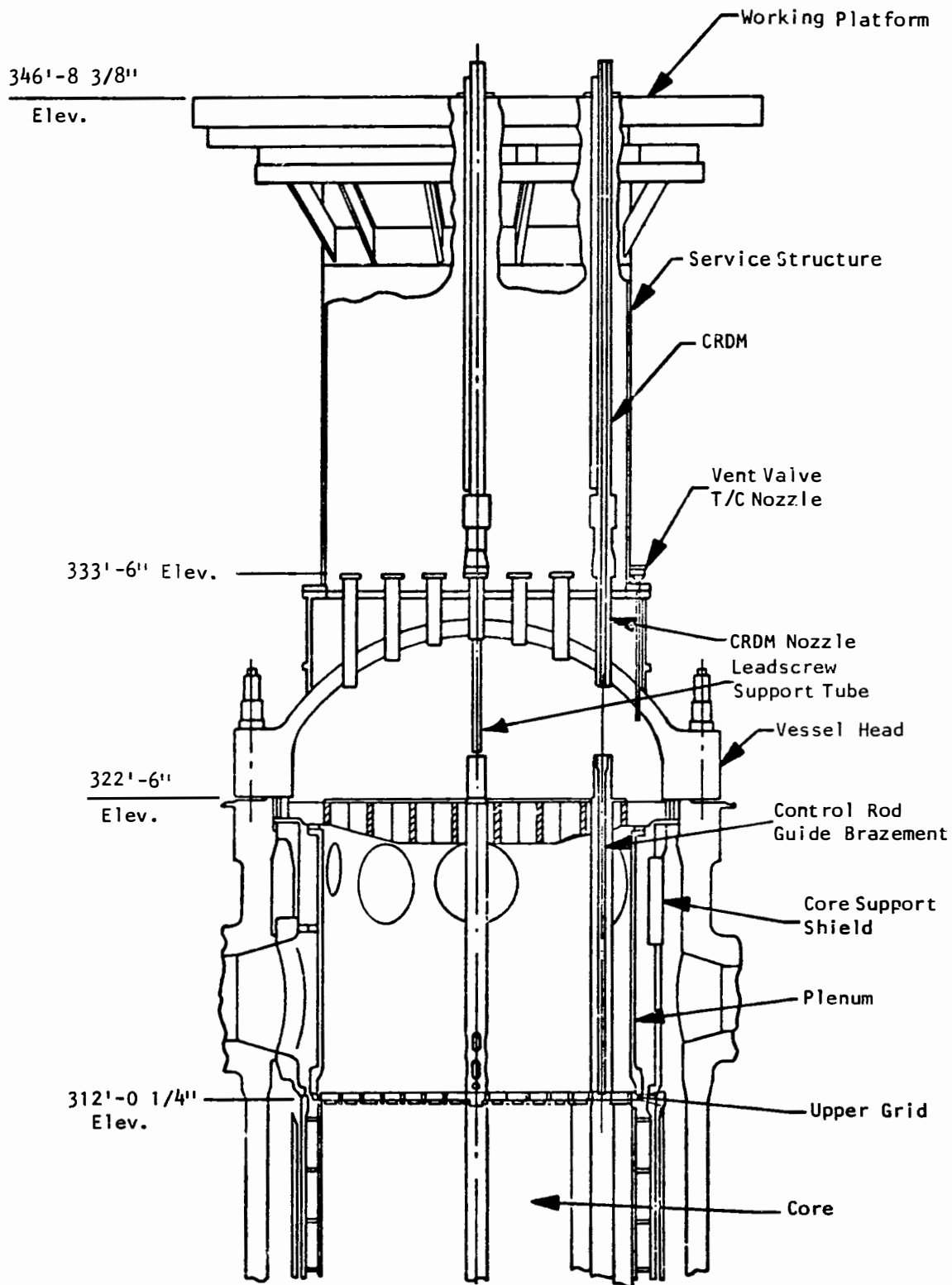

For manipulator operation, a leadscrew clamp (shown in Figure 4-26) is assembled onto the rotating arm on the lower end of the manipulator. The battery box and control light are assembled onto the upper end.

The manipulator and clamp are lowered into the RV through the MST until an adjustable stop on the manipulator rests on the support tube. The lower arm and clamp are then rotated to a horizontal position. The adjustable stop is moved and the manipulator is lowered until it rests on a capture nut, which permits up and down movement of the entire manipulator.

Counterclockwise torque on the manipulator permits adjustment of the two "centering" controls to ensure that the tool remains centered. The capture nut is used to lower the manipulator until a microswitch opens, indicating the clamp has contacted the top of the control rod guide tube. At this point, the control light is de-energized, signaling to stop downward movement. This elevation is then set on a height gage at the top of the manipulator and the clamp is raised 0.375 inch until it captures the leadscrew. A second microswitch then re-energizes the control light, indicating capture, and the radial capture position is set on the indicator located on top of the manipulator. Tension is then applied to the clamp release cable. This rotates a pin on the clamp arm, which frees a spring-loaded pin in the clamp. The spring pin moves tangential to the leadscrew and locks the clamp in place on the screw while permitting radial movement of the clamp.

The clamp and arm are separated by raising the manipulator using the captive nut. The clamp is rotated downward to the brazement by utilizing a pin-and-link arrangement on the arm along with manipulator rotation. After the clamp has been lowered, the manipulator is removed from the support tube.

4.2.4.2. Plasma-Arc Cutting Manipulator

The plasma-arc cutting manipulator (shown in Figures 4-26, 4-27, and 4-28) is made in two sections from 1.0 x 1.62-inch aluminum bar stock using pin joints similar to those in the clamp manipulator. However, these sections must be assembled in the vertical position. There are three control cables, two centering cables, and one rotating cable running along the outside of the sections. Four tubes which supply gas, pilot-arc power, and cutting head coolant are attached to a rotating arm on the lower section of the manipulator and long enough (100 feet) to reach the plasma-arc control console on the operating floor.

Figure 4-26. Underhead Plasma Cutter and Clamp

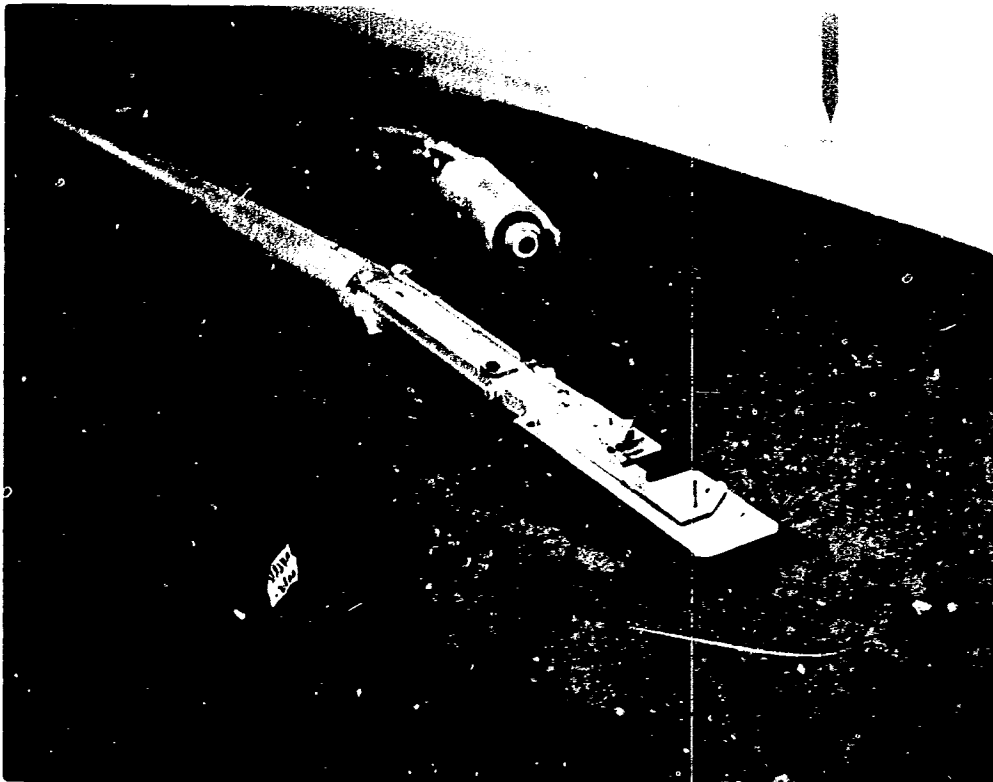

Figure 4-27. In-Head Leadscrew Cutting Tools

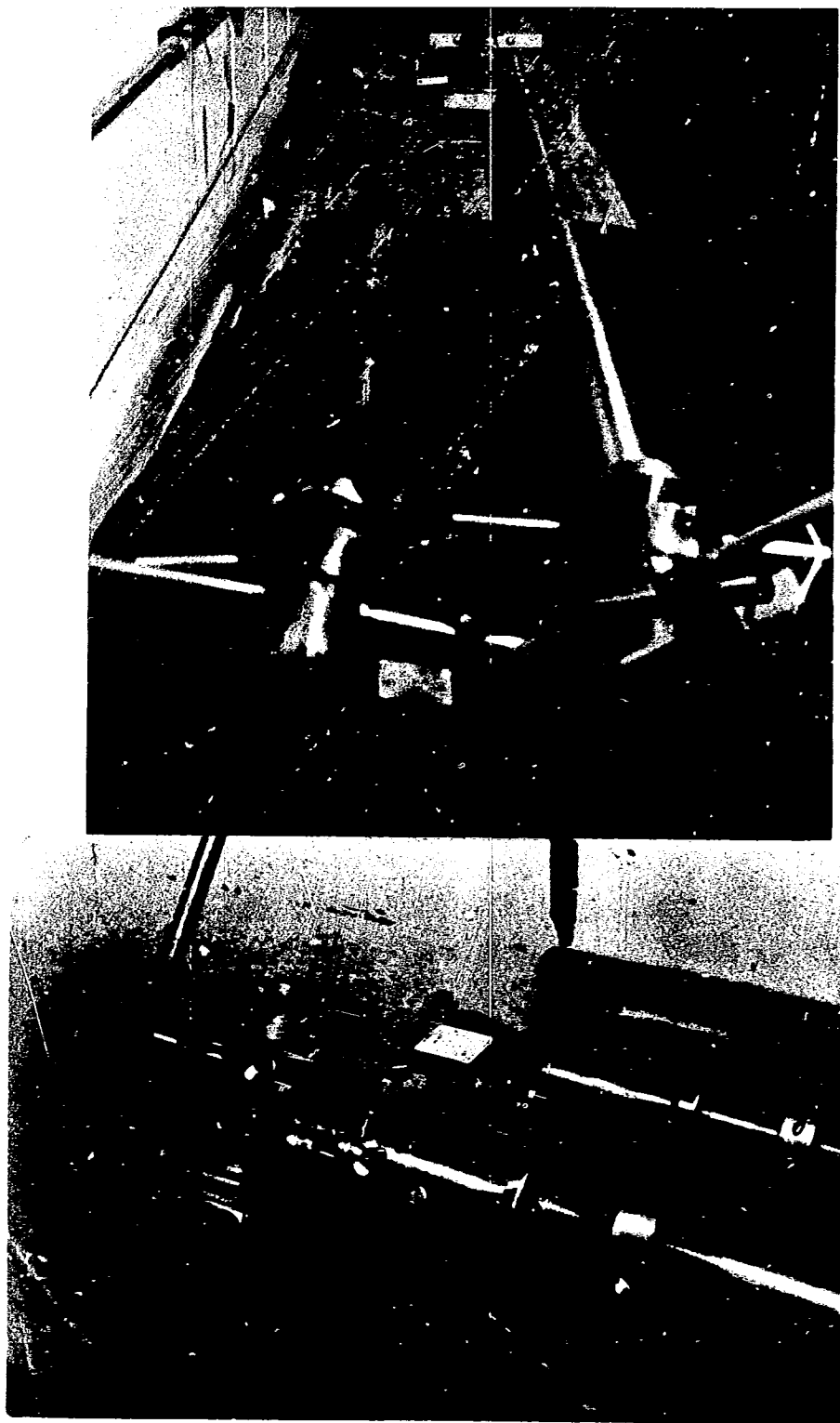
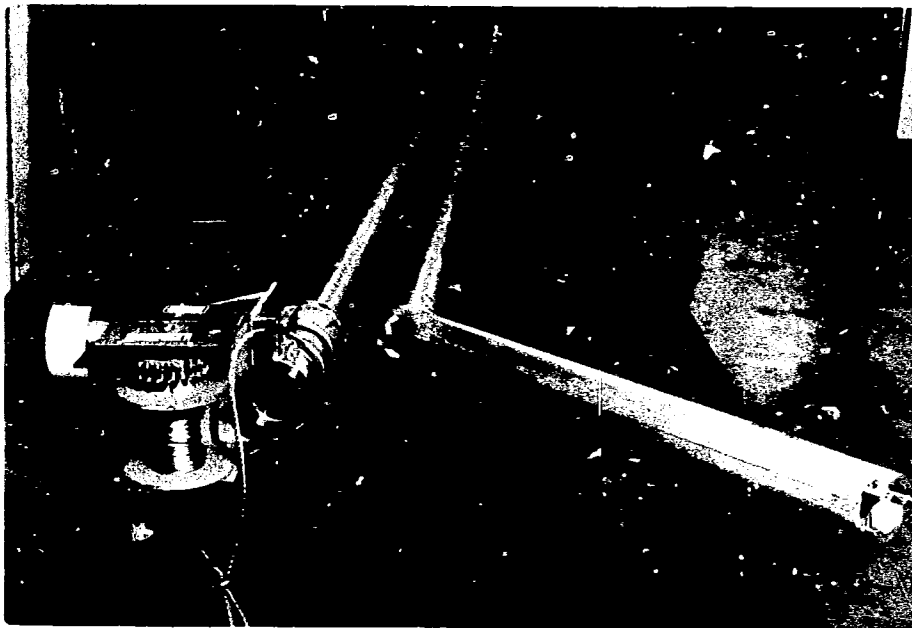
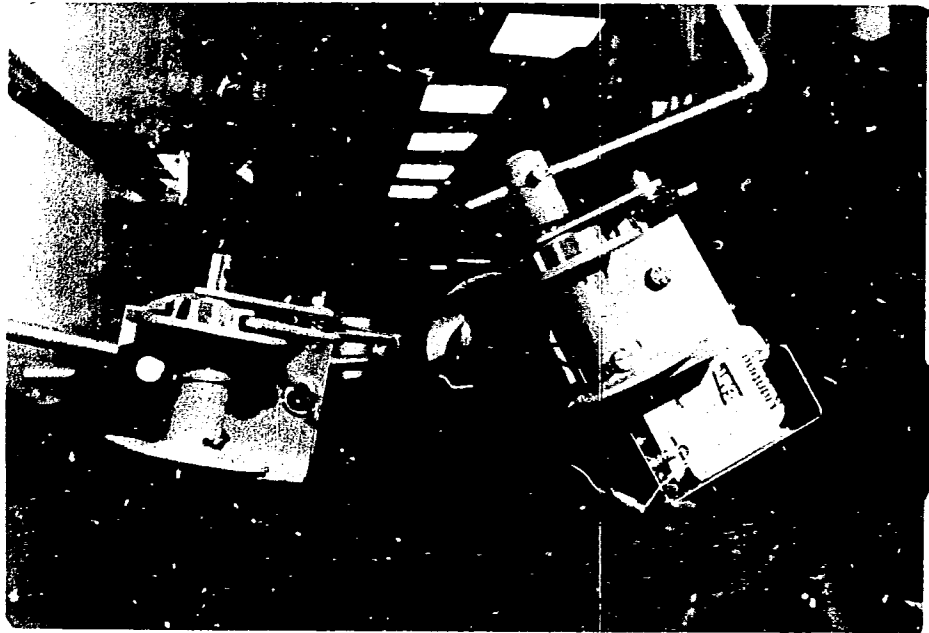

Figure 4-28. In-Head Leadscrew Cutting Tools



A lifting adapter is connected to the top of the lower section to permit insertion in the support tube. The lower section is lowered until it rests on the detachable stops positioned on its upper end. The top section is brought into position and connected to the lower section. The manipulator is then lowered to a set position, where the stop is reinstalled. The tubes are fed into the support tube when the manipulator is lowered into position. The lower arm is rotated and the manipulator lowered (using the capture nut) to a preset position using the techniques described in section 4.2.3.

A stop on the front end of the plasma-arc cutting head prevents the torch from getting too close to the leadscrew. By rotating the manipulator to the present radial mark and using the "centering" controls, the head can be properly adjusted in relation to the leadscrew. The gas hoses are connected to the console, the pilot-arc control cable is routed to the manipulator operator, and the grouped cable is connected to the leadscrew to be cut.

The leadscrew is cut by rotating the manipulator past the leadscrew while holding the pilot-arc switch in the ON position and following the instructions for plasma-arc operation. After the leadscrew has been cut, the CRDM may be removed from the nozzle.

4.3. Video Equipment

The video equipment includes necessary electronic and mechanical devices for viewing inside the RV. This equipment includes underwater cameras and control units, auxiliary lighting for both underwater and in-head use, the bag attachment for underwater viewing in turbid water, and manipulators to position the cameras and lighting.

4.3.1. Television Equipment

The underwater camera provides the means for obtaining visual information on the condition of internal components of the reactor. By positioning of the camera head with pull cables and the camera manipulator, such areas as the top of fuel assemblies, the plenum cover, the guide tube brazements, and the inside of the RV head can be observed. With an auxiliary camera, the movement of the manipulator arm and camera head can be observed to aid in proper positioning of this equipment. Using optional video tape recorders, a permanent record can be obtained for future reference. An optional video monitor with a larger screen than that provided with the camera control unit would also increase viewing resolution.

The camera assembly and control unit is a Westinghouse Model ETV-1250. The major components include the camera head and integrated control unit connected by 125 feet of cable (see Figures 4-29 and 4-30). The ETV-1250 is a complete underwater video system specifically designed for nuclear reactor inspection. The majority of the system electronics are housed in the control unit, thereby minimizing the components exposed to the reactor environment.

The camera head is 12 inches long and 1.25 inches in OD. This unit contains a field-effect transistor video preamplifier, the camera tube, lenses, and a remote focus motor. These components are grouped into a complete subassembly that can be easily removed from the camera head, allowing quick repair. This subassembly is housed in a 316 stainless steel case. The camera head is rated for a gamma dose rate of 2×10^6 R/h for a cumulative dose of 10^8 R.

The camera control unit consists of a 4-inch monitor and contains all electronics not located in the camera head. The electronic circuitry includes video processing, light control, rotating right-angle viewing attachment motor control located on the front panel. Connections to external equipment, such as monitors and video tape recorders, are available.

The ETV-1250 has a full line of accessories including a lighted axial viewing attachment with two 20-watt tungsten halogen lamps; a lighted, fixed, right-angle viewing attachment with two 20-watt tungsten halogen lamps; and a rotating right-angle viewing attachment complete with a 150-watt tungsten halogen lamp.

4.3.2. In-Head and Underwater Lights

Auxiliary lighting is provided because the integral camera lighting output is not sufficient for broad area viewing. The manufacturer indicates that integral lighting is not designed for viewing objects beyond 2 feet. The camera integral light is designed for underwater use and will overheat and may destroy other components if used in air. Therefore, additional lighting for both upper head and underwater viewing has been supplied.

Two auxiliary lighting units have been developed for use inside the RV. The first is a modification of a standard underwater light. The modification replaces the large protective lexan cover on the light with a wire screen and protective braces. An inner protective glass cover has also been removed to promote heat conduction from the bulb. These modifications reduce the diameter

Figure 4-29. Camera Control Unit

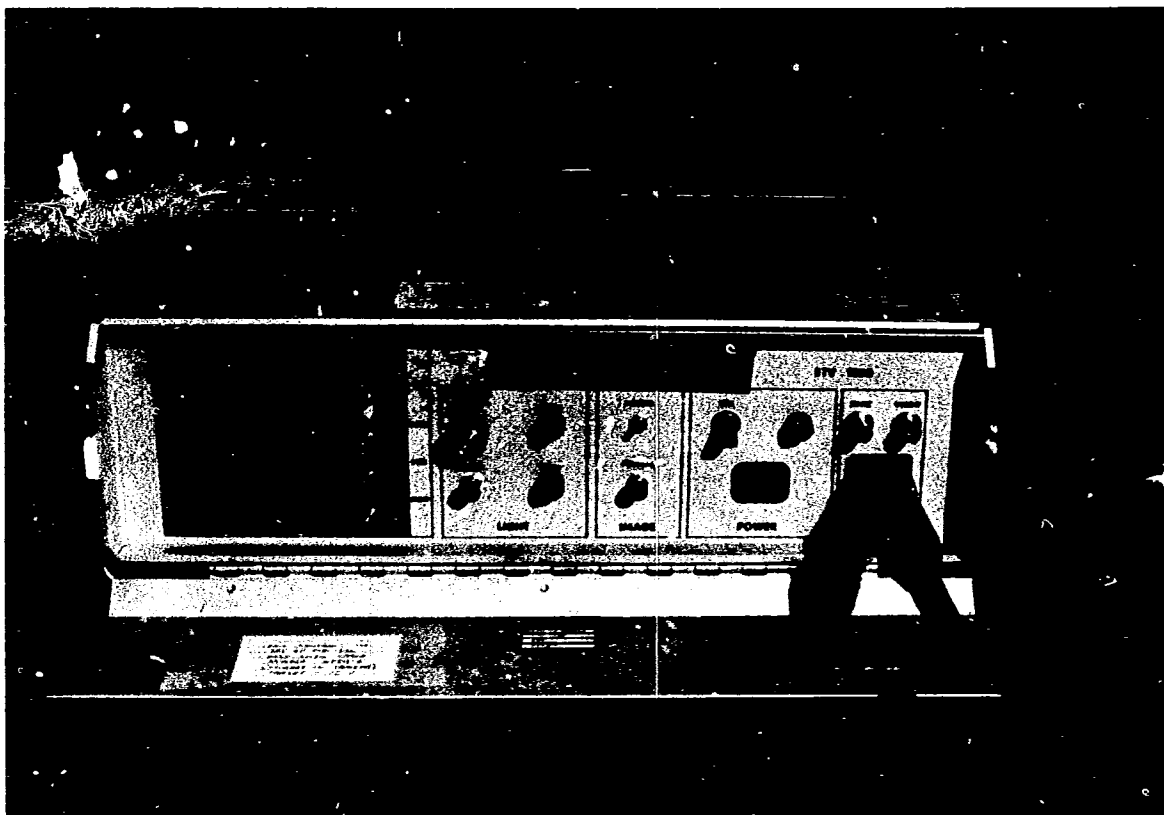

Figure 4-30. TV Camera Head



and permit the light to pass through the 2.765-inch CRDM nozzle with a 250-watt lamp. This light is used for upper head illumination in air.

The second light is for underwater use. It has an OD of 1 inch and is inserted in the camera manipulator (behind the camera) and follows the camera into the RV. This light uses a 250-watt bulb. Both lights have 100-foot electrical cords.

Variacs are used to control light intensity of both lights. The variacs are equipped with limit switches set at 100 volts to reduce the possibility of overpowering the bulbs. The variacs are adjustable between 0 and 100 volts and have safety fuses to eliminate the chance of shock should a bulb be damaged underwater (see Figure 4-31).

4.3.4. Murky Water Viewing Equipment

The possibility exists that the reactor water may be murky due to suspended particulates. If this occurs, the usefulness of the regular underwater camera would be limited due to the reflection of light from suspended particles in the water. An aid to this potential concern consists of attaching a plastic bag in front of the video camera and inflating it with clear water. When the bag is brought into contact with the object being viewed, it is possible to obtain improved video pictures even though the water in the RV is murky. This attachment is shown in Figure 4-32.

Clear water is fed to the viewing bag through 0.25-inch-ID tygon tubing, while air is released through a similar second tube. The tubes are connected to a double header system which allows the clear water to enter through the rubber collar to the lower reservoir created by the viewing bag, while at the same time venting the trapped air. The rubber collar creates the necessary seal around the camera, bag, and tube by being pushed and expanded by the ring and ring pusher which screws into the back of the tube. The other end of the rubber collar is secured by the inner ring of the tube. Two-thirds of an ounce of clear water is required to raise the water column in the two hoses 1 foot. Twenty ounces of clear water is required to fill the lower reservoir. B&W recommends filling the two hoses to a vertical height of 2 feet above the reactor water line to produce approximately 1 psi pressure. This pressure is required to keep the bag inflated while pressed against the object being viewed. The predetermined amount of water is held in an upper reservoir with

Figure 4-31. Underhead Special Lighting

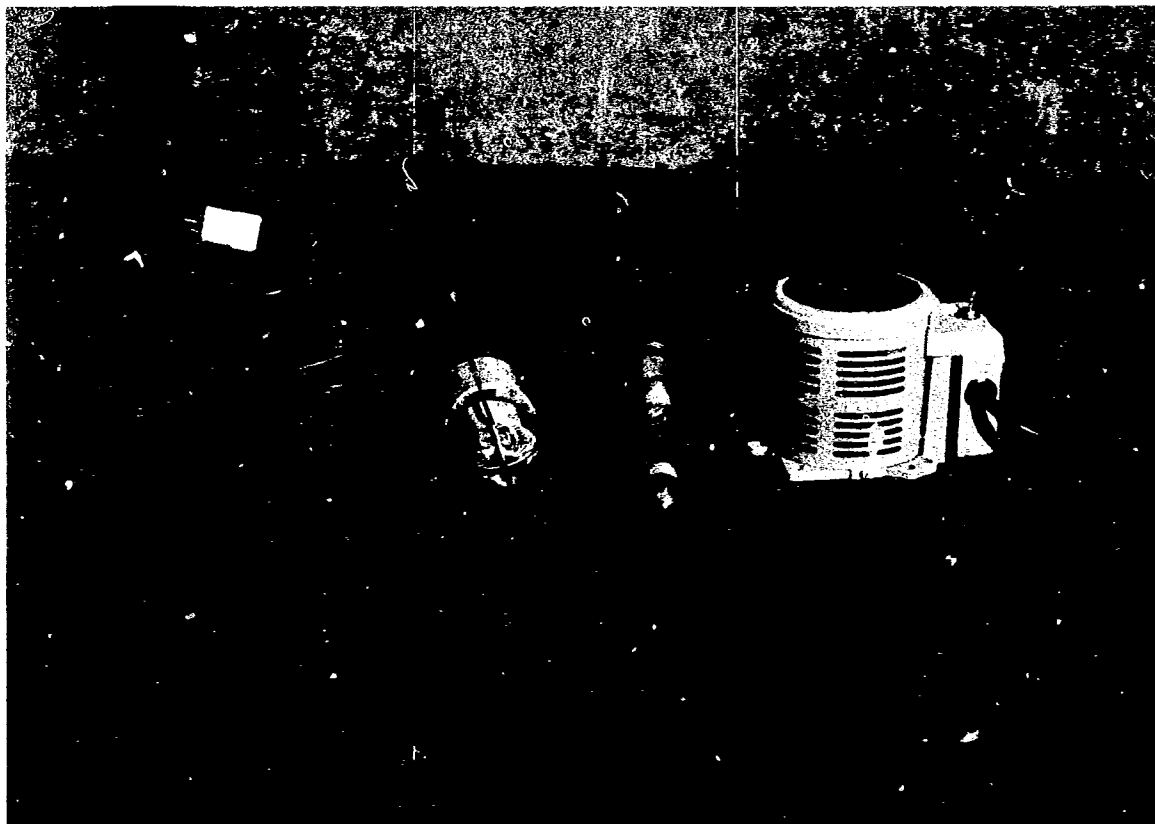
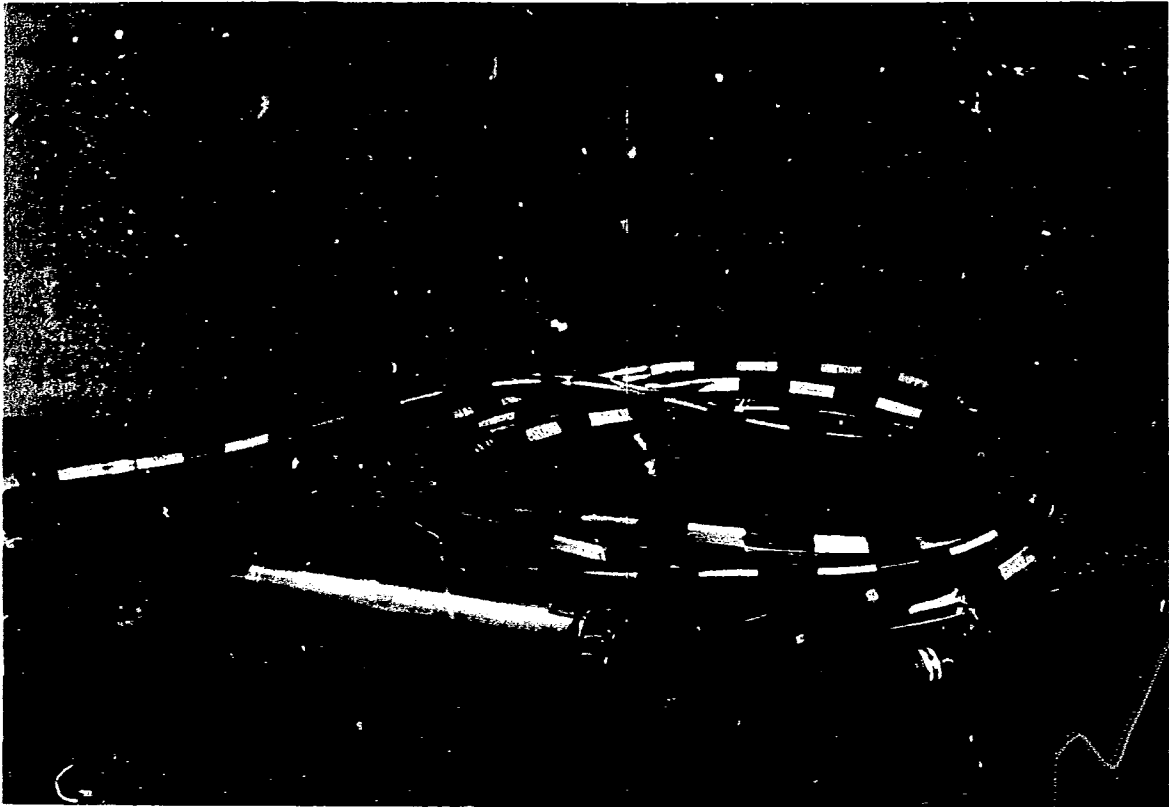

Figure 4-32. Camera With Shield



a petcock. Once the camera has reached the proper depth, the petcock is opened and the water is allowed to enter the inlet hose.

The murky water viewing equipment has been pre-assembled to save time in the field. Approximately 40 feet of camera cable and tygon tubing have been taped into a single unit to avoid tangling. The area around the headers has been encased in heat-shrinkable tubing to reduce damage to the headers and reduce the possibility of tygon tubing separating from the headers. The tube can be removed from around the camera for repair by unscrewing the ring pusher from the tube and pulling the tube out, away from the camera. Bag replacement is possible, and spares are supplied.

The murky water video system will be employed only if acceptable data cannot be obtained without the bag. B&W expects only limited results using this technique. The field of view will be limited to the size of the plastic bag, and depth of view will be limited. Investigation of upper end fittings through the brazements is not possible using this system.

The plenum cylinder can be viewed with the ETV-1250 underwater camera from above the water level in the vessel if certain conditions can be met. The water turbidity must be clear, and proper lighting is essential. Depending on where the source lighting originates, reflections may appear in the picture, obstructing the viewing area and washing out the picture. However, if the glare off the water surface is not directly pointed at the camera, it will be possible to view the plenum cylinder.

4.3.5. Camera Manipulators

The camera manipulators are designed to position the camera and underwater lights in selected areas inside the reactor. One area, on top of the fuel assemblies, requires no movement of the manipulator movable arm. To reach the second area, the peripheral fuel assemblies, the movable arm must swing out until the camera can be dropped just past the plenum cover and inside the plenum cylinder down to the fuel assemblies. The third is inside the head. To permit observation of the plenum cover, brazements, and dome, the movable arm must be capable of complete 180 degree rotation and a horizontal position. A fourth area is the space between the plenum cylinder and the core support structure.

Manipulator parts include the winch; upper, lower, and movable tubes; and a pull cable (see Figure 4-33). The winch is a Thern, Inc., 1/4-ton reel winch, Model 401. The factory-equipped handle has been replaced with a large wheel to facilitate winding. An adapter for a twist drill connection to wind excess pull cable on or off the winch bail has also been provided. The upper, lower, and movable tubes are constructed of aluminum tubing to minimize weight. The upper and lower sections are connected with a positive coupling to reduce twisting of cables during assembly and disassembly. The movable tube section has been pinned to the lower section to prevent free rotation of the movable tube section. The movable tube consists of a threaded section that connects to the lower tube and a hinged section below that. The pull cable is connected to the open end of the movable tube and runs inside for approximately 3 inches. The cable exits through a hole in the tube wall and runs outside the movable tube through a cut groove to the hinged area. Here the pull cable is threaded back inside the lower and upper tubes until it exits the top of the manipulator. At the top, the pull cable is wound around the winch bail and secured. By turning the winch handle in the proper direction, the pull cable exerts a force on the end of the movable tube to move the arm.

Two manipulators are provided, each with its own function. One manipulator is used with the murky water equipment; it has vertical positioning markers available for insertion into the MST. The other manipulator is used with the regular camera and underwater light equipment.

4.4. Swipe Tool

The swipe tool takes swipe samples of debris that may be present on the plenum cover (see Figure 4-34). The body of the tool is constructed of 1-inch-square aluminum tubing. It is divided into upper, middle, and lower sections, making the tool foldable to permit transport and easy storage. Its three sections are assembled with overlapping sleeves and quick release mechanisms in two places. The lower section contains two hinged tubes that enable positioning the sampler outside the guide tube. The hinged tubes are controlled by two 0.125-inch-diameter stainless steel cables that are guided for the length of the tool by small-diameter aluminum tubing sections welded to the tool body.

The lower hinged joint contains the sample insert and insert holder. The insert holder holds the swipe material, a cotton cloth with sponge backing. It has a facial area approximately 1 inch in diameter. The insert holder protects

Figure 4-33. Underhead Camera Manipulator

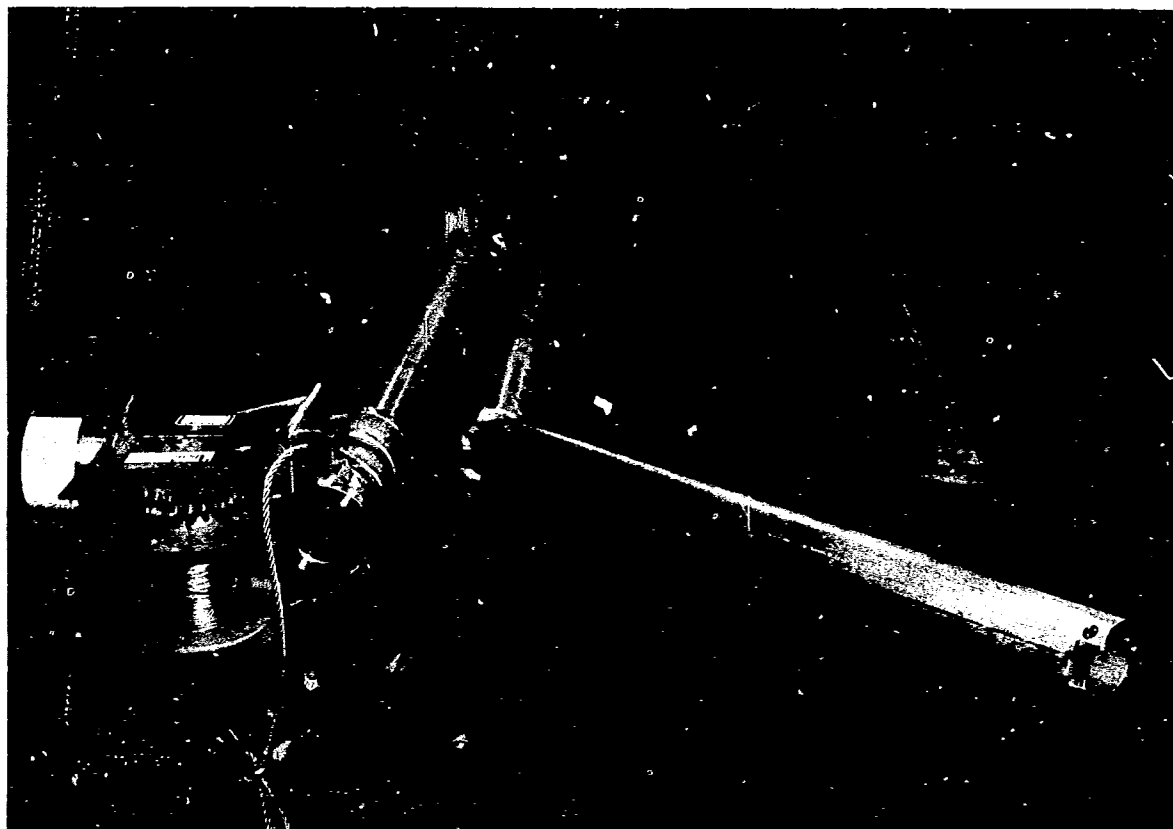
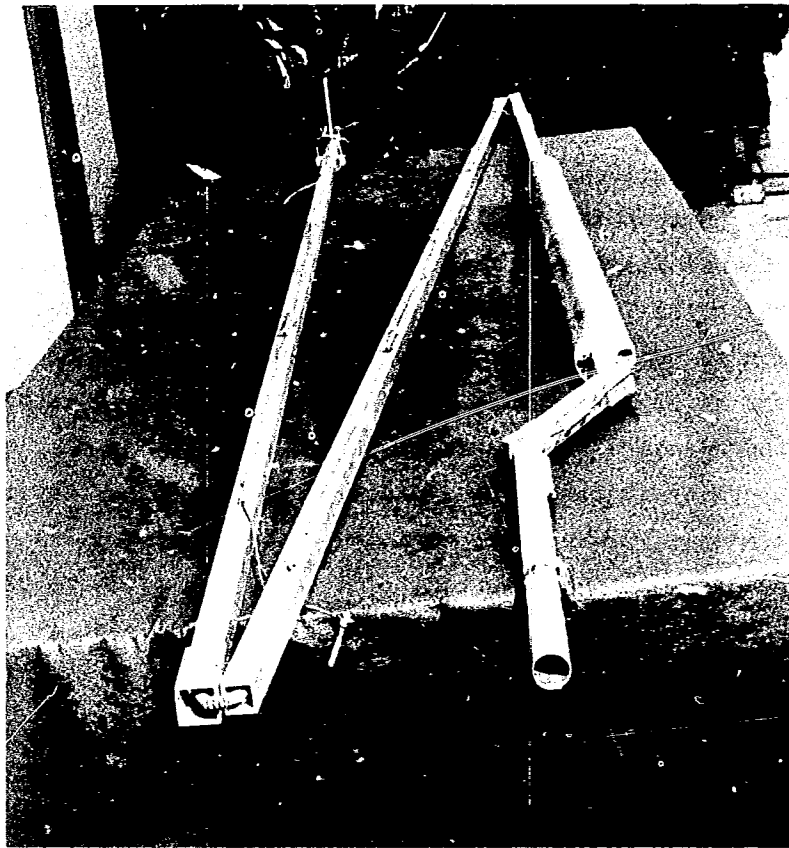

Figure 4-34. Plenum Cover Sample Tool



the swipe once the sample taken. The insert with swipe and insert holder comes as a packaged unit and is easily attached to and disassembled from the tool.

The swipe is operated by a stiff wire inside the tubing. The upper end of the wire contains a T-handle and holddown bar that latches into slots in the upper tube section to lock the swipe in the engaged position. The wire also has flexible sections at each hinge and break point of the tool.

To ensure true rotation of the MST, a 3-foot-long aluminum cylinder is fixed to the bottom of the tool. The clearance between the MST and the cylinder is small, ensuring that the rotation of the swipe tool is circular around the brazement. This reduces the possibility of repeating swipes in the same area.

In operation, the tool is guided down through the MST until the guide tube brazement is reached. Sequentially, the pull cables are operated and the tool is lowered the additional distance to reach the plenum cover. The swipe is then engaged by pushing the T-handle down and locking it into place. The swipe sample is taken by moving the swipe material over the face of the plenum cover by rotating the swipe tool inside the MST. Once the swipe is taken, the swipe sample is withdrawn into the insert holder to protect the sample. The tool is retrieved by reversing the installation procedure. The insert holder, with internal swipe sample, is detached from the tool and stored. A new swipe and insert holder are then attached to the tool, and it is ready to take the next swipe sample.

Depending on the amount of material deposited on the swipe cloth and the tool, sample withdrawal may invoke significant potential radiation levels. Consideration should be given to designing a shielded sample container for withdrawing the sample. An alternate concept is to use the MST as a temporary sample container for removing the sample to a shielded cask.

5. MOCKUP DESCRIPTIONS AND TEST RESULTS

Mockup testing was conducted using the facilities at Diamond Power Specialty Company (DPSC) in Lancaster, Ohio, and B&W's Special Products and Inspection Services (SPIS) and Lynchburg Research Center (LRC) in Lynchburg, Virginia. Tools tested at DPSC were the stator tool, bolt tool, manipulator support tube, in-head and underwater lights, swipe tool, manipulators, murky water viewing attachment, blind flange lowering tool, and underwater camera system. The purge and water levels systems were mocked up at the SPIS facilities. Mockup tests on the leadscrew clamp and manipulator, plasma-arc cutter, and leadscrew puller/separator tool were performed at LRC.

Two separate mockups were used at the DPSC facilities. The reactor mockup consisted of two parts. The lower mockup included the plenum cylinder, guide tubes, and plenum cover with three brazements, while the upper part consisted of the head and three CRDM nozzles. Both sections were constructed of wood and set in a large tank approximately 6 feet in diameter and 10 feet high. The three CRDM nozzles simulated three adjacent nozzles on the perimeter of the reactor vessel. The tank was filled with water to a level of 6 inches above the plenum cover to simulate the expected water level during inspection in the TMI-2 reactor. The second mockup simulated the space envelope available for use with the stator tool. Two adjacent CRDMs with stators were simulated by aluminum cylinders. The area at the stator housing elevation was considered to be the most restrictive. This mockup was constructed utilizing an existing CRDM on the test autoclave. An existing upper level grating simulated the service structure for both mockups. The grating around the CRDM was cut to simulate the 12-inch-square hole in the service structure left when the seismic plate is removed. A 3-foot-high wooden platform was constructed at the three MSTs to simulate the service structure level more accurately.

Two small mockups were assembled at SPIS to test the water level and purge systems. To simulate the water level in the reactor, a 6-foot PVC tube with a plugged bottom was set vertically and filled with water. A piece of tygon

tubing was used to simulate the bubble pipe. Water level was changed by moving the tygon tubing up and down inside the tube. To simulate the RV for the purge system, a wooden mockup volume chamber was constructed containing three holes to represent openings in the MSTs. Four thermocouple nozzles were attached to the side of the box to simulate the thermocouple interface to the purge system. A pressure gage and manometer were used to monitor pressures inside the mockup.

The leadscrew puller/separator was mockup tested at the LRC. The tool was assembled vertically and held with hose clamps, and the bottom of the tool was set on a small stand to give the proper height. The pins to be sheared were put in place. The leadscrew assembly was then fed into the push/pull tool in a horizontal position and this assembly raised to a vertical position and secured. A wooden frame approximately 3 feet wide by 6 feet long was constructed and secured to the railing the proper distance from the tool to simulate the hole in the service structure. A 4-inch-high platform was also constructed to provide the proper vertical height in relation to the tool. The leadscrew puller/separator operation was also demonstrated at DPSC.

Mockup testing performed at DPSC was done in full anti-C clothing, including respirators. The purge and water level system tests at SPIS were operational tests to verify system operations. Tests performed at LRC were conducted with anti-C gloves to simulate handling conditions.

Data were collected on the time required to perform various operations during mockup demonstrations (these data are included in Appendix B). This information can be used as a guide to ALARA evaluations when preparing detailed procedures for the operations.

5.1. Diamond Power Specialty Mockup

Several tools were demonstrated for a combined group of DOE/EPRI/NRC/GPU members at DPSC on August 21, 1981:

1. Swipe tool
2. Manipulator support tubes.
3. Underwater lights.
4. Modified hydro lights.
5. Stator lifting tool.
6. Camera and light manipulator.

7. Murky water viewing attachment.
8. Bolt removal tool.
9. CRDM blind flange tool.

All demonstrations were performed in full anti-C clothing, including full masks. Figures 5-1 through 5-5 illustrate mockup testing at DPSC.

The swipe tool was lowered into the MST and then engaged. A swipe of debris was then taken off the plenum cover and the swipe tool withdrawn. It was shown that the swipe sample could be retrieved inside the holder and detached from the swipe tool.

The MSTs were prestaged for the demonstration. They were placed on the wooden mockup of the reactor and bolted to the CRDM nozzle. The upper end of the MSTs were supported by the grating at the service structure level.

The underwater and in-head lights were demonstrated along with the underwater TV camera system. The in-head lights provided adequate lighting for in-head inspections and monitoring of manipulator and camera movements. The underwater lights also provided some additional lighting, especially when the camera was equipped with the low wattage bulb. The underwater camera gave good, clear pictures of the in-head area, the top of the fuel assemblies, and the peripheral fuel assemblies. The camera and light manipulators were also maneuvered so that the camera and underwater lights could be positioned in the position for the desired inspections.

Demonstration of the stator lifting tool showed that the stator could be removed from the CRDM and removed from the tool. It was also shown that the stator tool could perform its functions inside the available space envelope.

The murky water viewing attachment was prestaged inside a container of murky water. The system demonstrated acceptable viewing capability when the bag was positioned over artifacts on the bottom of the container.

The demonstration of the bolt tool included positioning the tool plate, passing the bolt tool through the tool plate, and engaging and detorquing two bolts. All bolt tool functions were satisfactory.

The CRDM blind flange tool demonstration was shown on video tape. It was shown that the blind flange could be lowered with the tool with four holddown bolts installed in the flange. The holddown bolts were then torqued using the normal bolt tool.

Figure 5-1. Diamond Power Mockup Facilities



Figure 5-2. Diamond Power Mockup Facilities

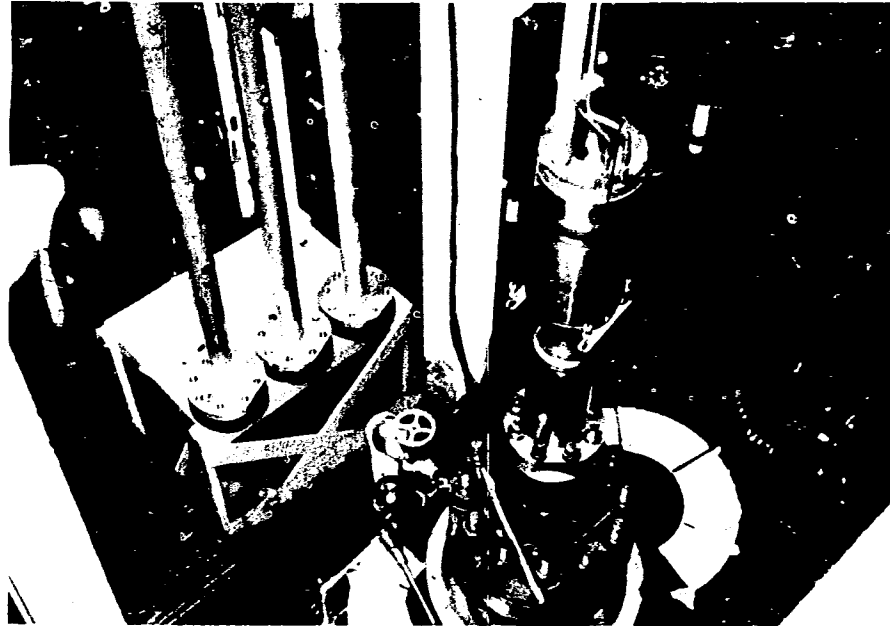

Figure 5-3. Diamond Power Mockup Facilities

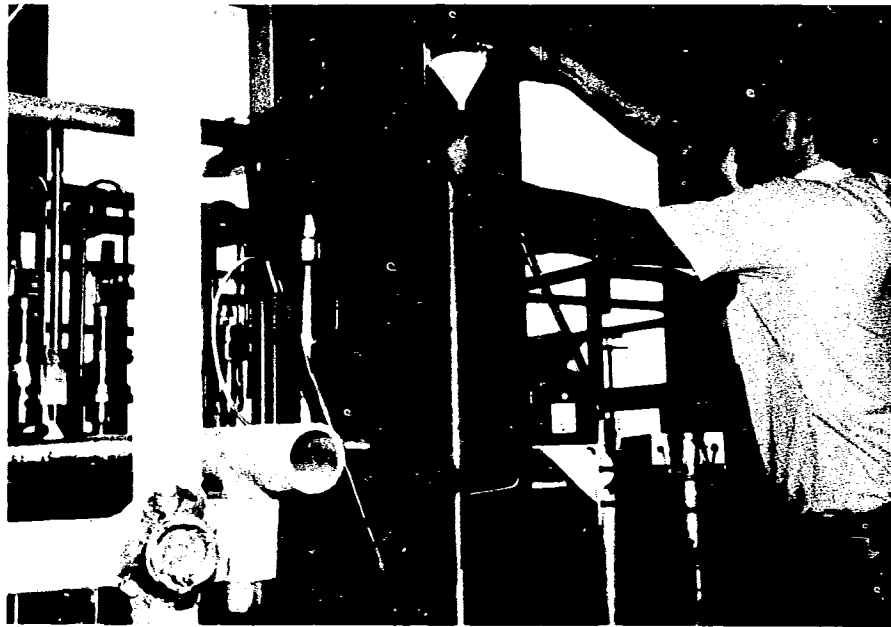
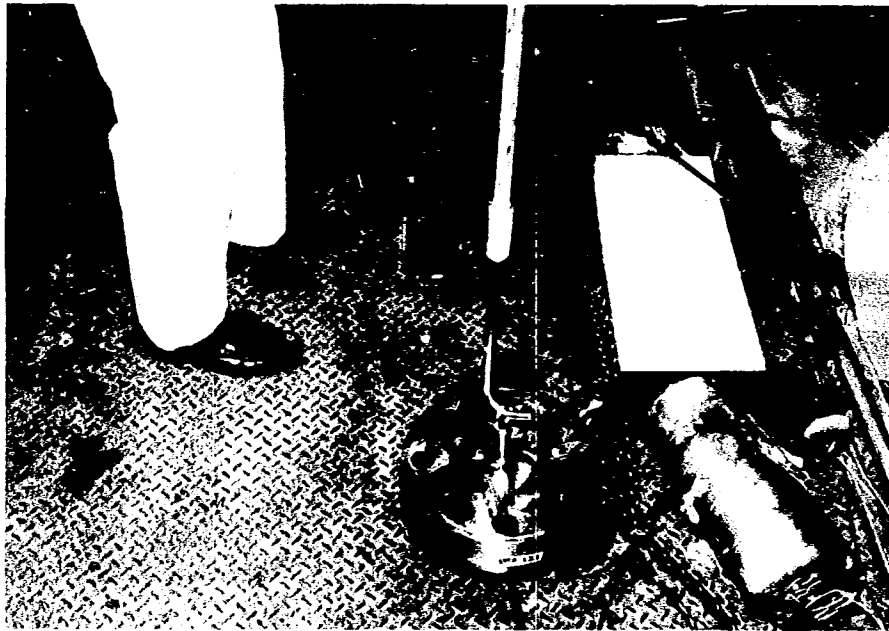

Figure 5-4. Diamond Power Mockup Facilities

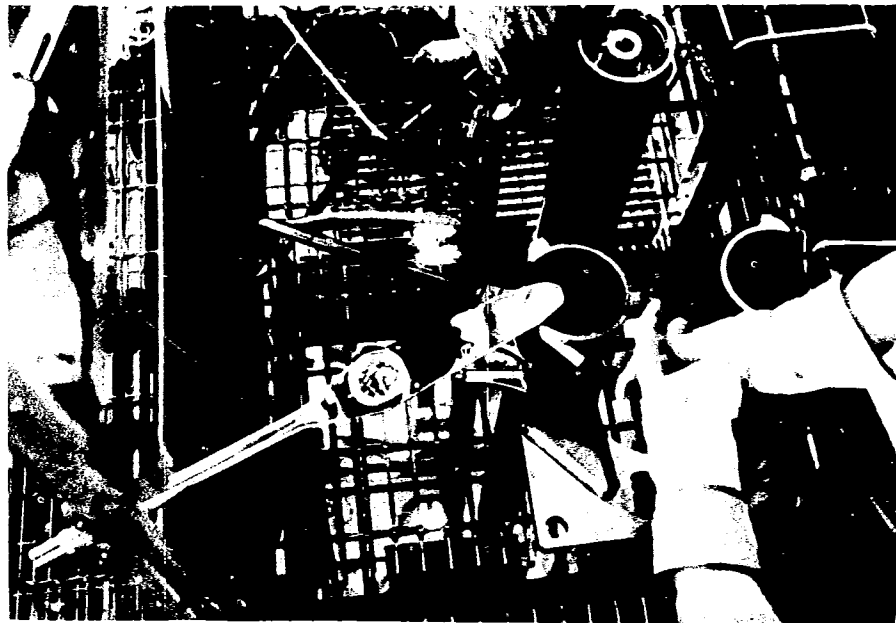
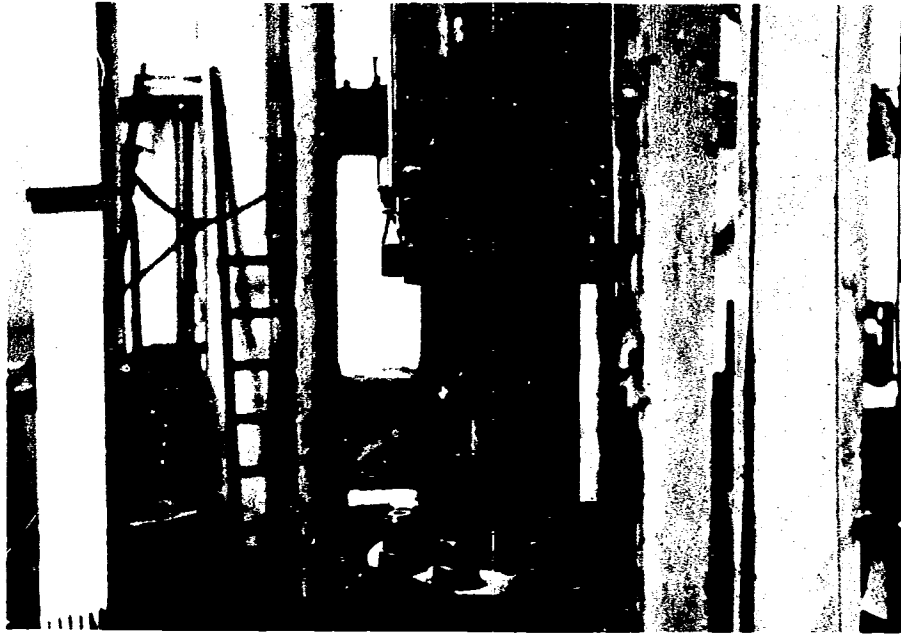
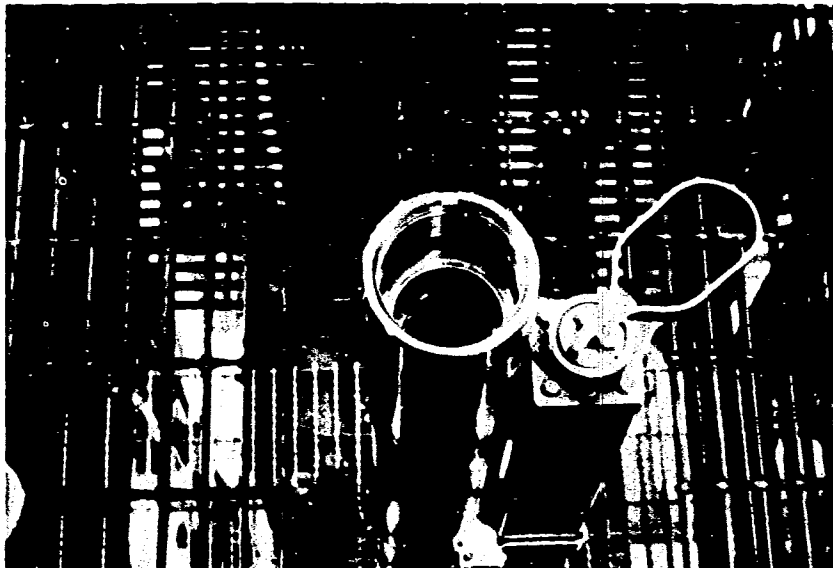

Figure 5-5. Diamond Power Mockup Facilities



Notable Tool Modifications

As a result of testing, design changes on the swipe tool resulted in improved structural integrity and increased maneuverability. The wall thickness of the square aluminum tubing, which makes up the body of the tool, has been increased to add stability. Quick disconnects have been added for ease of assembly and disassembly. To eliminate damage to the push rod inside the tubing, flexible cables are now present at each hinged joint and disconnection point. The lower leg of the tool has been lengthened to ensure contact of the swipe with the plenum without interference of the brazement. Vise-grips were found useful to hold the swipe stationary while inserting and extracting the tool from the CRDM dummy motor tube. Small eyes in the original design are replaced by sections of small ID tubing as guides for the pull cables. To produce a true circular rotation of the swipe about the brazement, a cylindrical bushing has been added to the lower end of the tool, which fits just inside the CRDM dummy motor tube. This cylindrical bushing also reduces the possibility of the pull cable guides being sheared off by contact with the CRDM dummy motor tube. The hinges were also doubled in size for added strength. Incorporation of these design improvements was essentially a total reconstruction of the swipe tool.

5.2. Ex-Head Mockup for Plasma-Arc Mockup Design and Construction

Figure 5-6 shows the configuration at the TMI-2 reactor head and service structure in the space where ex-head plasma-arc cutting may be accomplished. It includes dimensions locating the work platform with respect to the leadscrew. Figure 5-7 shows the physical constraint mockup for demonstration of ex-head operations. The mockup was located in an outside area at the LRC with the plasma-arc console inside the nearby building.

The mockup was constructed using angle iron to form a frame with a metal plate top. The top provided a mounting surface for support members that were adjustable to permit the simulated CRDM flange to be raised and obtain the required 5-inch gap between flanges (see Figures 5-8 and 5-9).

Both flanges had the proper holes and chamfers required to permit installation of sample leadscrews and support tubes. Provision was made to clamp the sample components above the top flange to prevent the top ends of the test pieces from falling into the molten cut area after a cut.

Figure 5-6. Location of Platform for Ex-Head Cutting

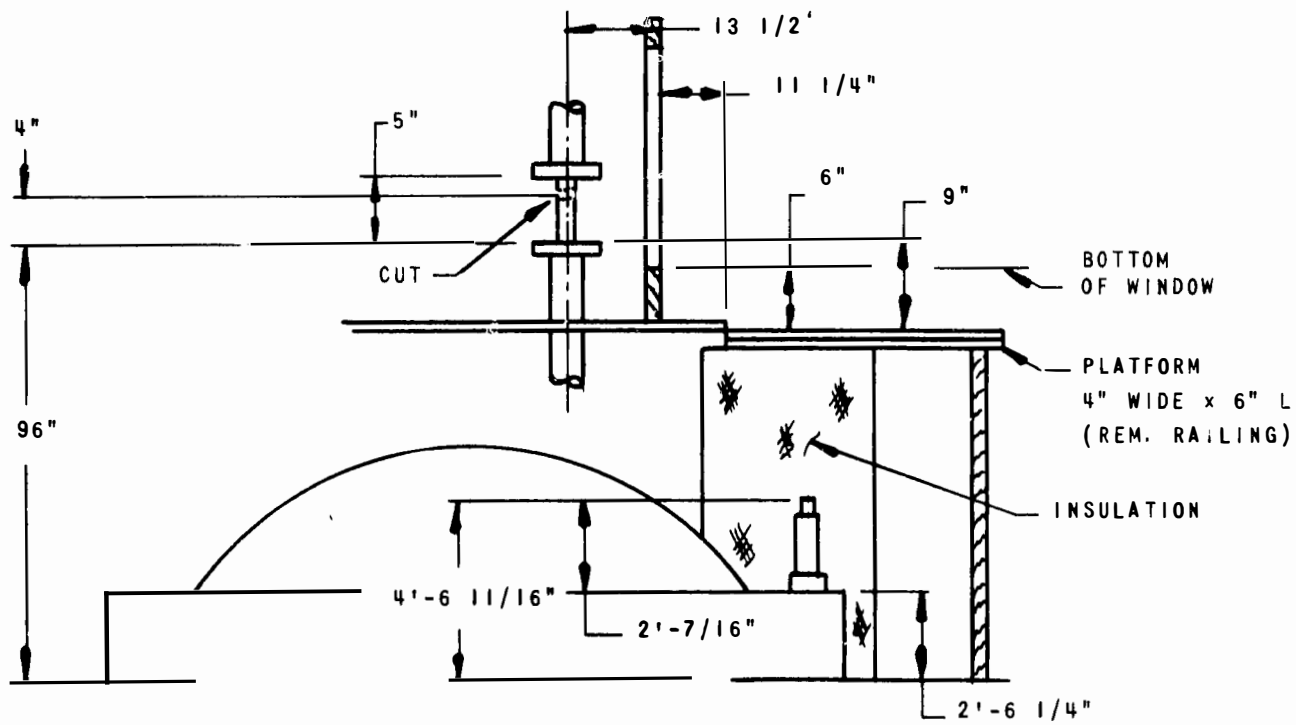
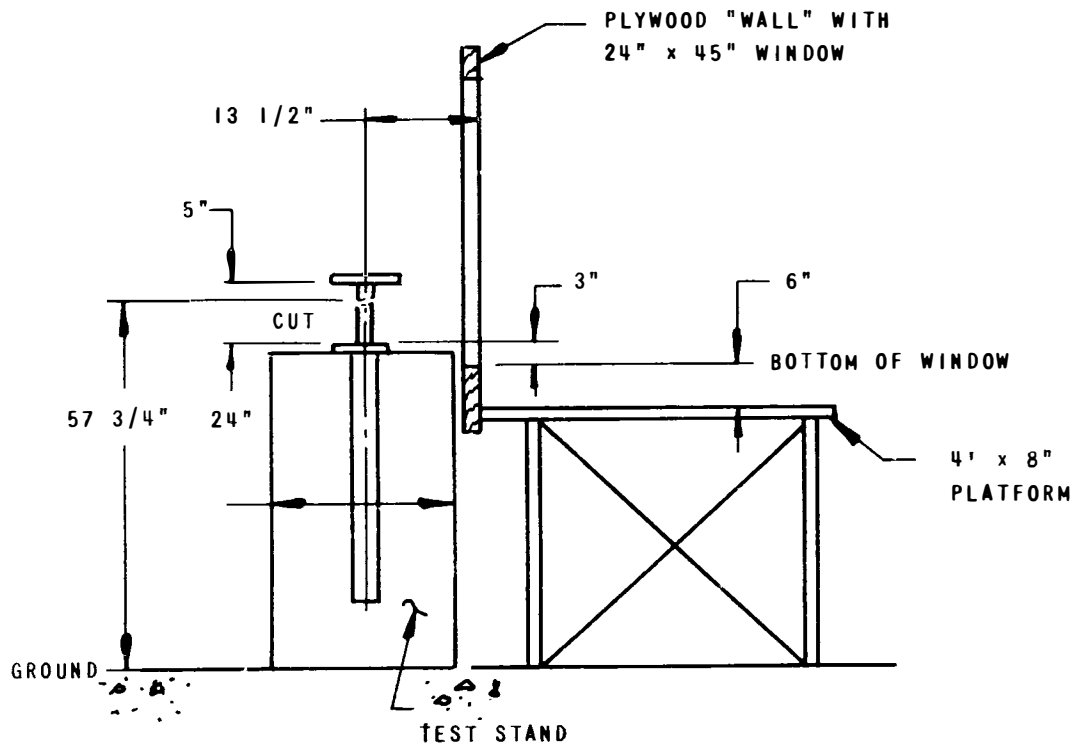

Figure 5-7. Mockup of Physical Constraints at RV Head



Vise-grip pliers were clamped around the end of the leadscrew extending below the mockup top plate. A stop was used to prevent the pliers and leadscrew from rotating. This also permitted a file and chisel to be used in cleaning the leadscrew.

Problems During Testing

Original test requirements permitted cutting while standing on ground level as shown in Figure 5-7. This would have required the removal of head insulation around the service structure and construction of a lower platform. The change resulted in the mockup as shown in Figure 5-7. The change required the operator to lie on the platform to see the cutting area. The prone position was awkward for cutting operations, and the difficulty was compounded by the interface of the welding mask with the standard breathing mask.

Bechtel also directed that the two-piece leadscrew support tube clamp be changed to a one-piece design to cut installation time. Improvements were also required in the flange cover and curtain assembly used to protect the nozzle flange top surface from molten metal splatter. A flame retardant curtain for an area 180 degrees around and between flanges was also provided.

It was not possible to obtain a burr-free cut on the leadscrew to permit threading the loose nut on the ends of the lowering and centering tool; hand tools were required to remove excess material on the upper portion of the cut leadscrew. Cleanup times from 30 seconds to 20 minutes were noted for various cuts. Thread dressing was accomplished using a hammer, chisel, and file.

Cutting with a hand-held plasma torch produced cuts whose quality varied with the gap between torch and specimen, machine settings, cutting time, and torch positioning. Proper machine settings and a cutting guide for setting the gap were developed. The ideal cutting time was determined to be 5 seconds. Three seconds resulted in an incomplete cut, while longer times led to excessive melting, leaving large "burrs" to be removed. Torch positioning involves the difficult task of holding the torch head and attached hoses in a horizontal position and maintaining this orientation while pulling the torch across the leadscrew; this must be accomplished while lying prone. These factors make it difficult to predict an exact cleanup time.

The flange cover and curtain assembly were redesigned to provide a 270-degree curtain coverage. They were also changed to provide flange protection with

Figure 5-8. Mockup of Ex-Head Leadscrew
Plasma-Arc Cutting

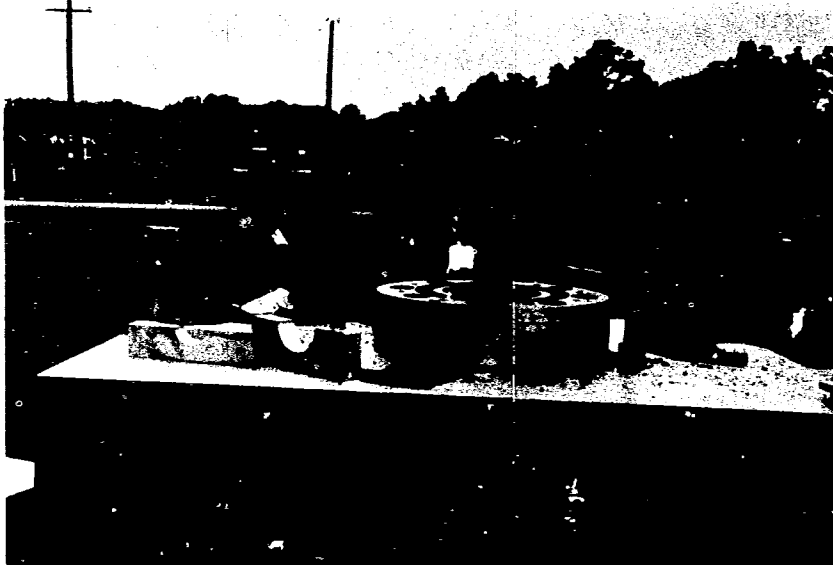
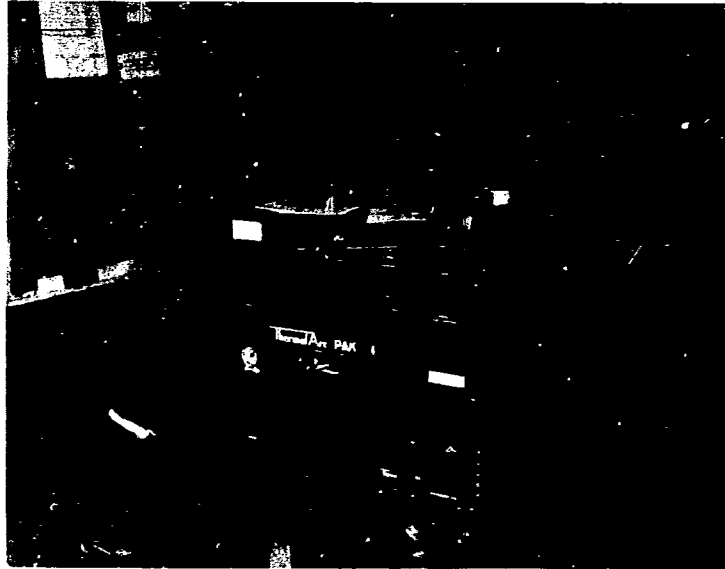
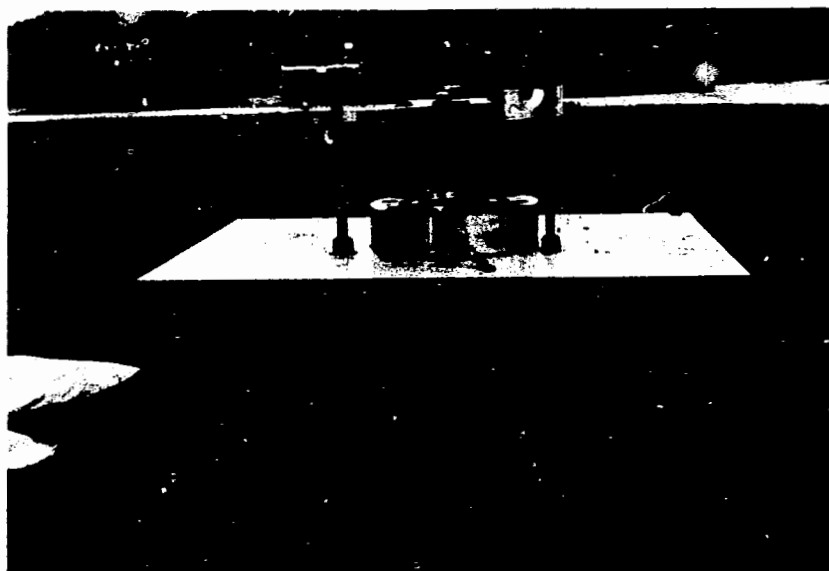

Figure 5-9. Mockup of Ex-Head Leadscrew
Plasma-Arc Cutting



the redesigned "one piece" leadscrew support tube clamp in place. Use of these new devices reduced cycle time.

Mockup testing was attempted with a 2.5-inch flange separation as well as with a 5-inch separation since a 2.5-inch separation may be all that can be achieved. Working within the 2.5-inch space appears to be impractical if clamping is required.

Testing also proved that the curtain method of preventing particulate distribution into the atmosphere was not adequate even though the flange protection provided was adequate. Bechtel decided the curtain would not be used. A decision was made by Bechtel to provide protection in conjunction with the system to be designed to protect against contamination resulting when plasma cutting the "window" in the service structure.

A leadscrew cutting demonstration was held at LRC using the mockup with no flange protection or curtain. The setup included a test piece of leadscrew clamped top and bottom with a sample piece of leadscrew support tube around it and clamped at the top so it could not fall when cut. A detailed procedure was followed and the tube was cut. The support clamp was installed and the tube was lowered to expose the leadscrew. After the leadscrew clamp was installed, the screw was cut. Two attempts to obtain a complete cut were made. Removal of the simulated flange along with the top portions of the tube and screw was accomplished next, simulating removal of the CRDM. The demonstration was stopped before complete "cleanup" of the leadscrew due to inclement weather. The quality of the cut was poor compared to past cuts, and it is estimated that cleanup would have required 7 to 10 minutes to permit installation of the centering and lowering tool. It was apparent that a qualified plasma-arc technician could be able to make an acceptable cut with some practice.

Anti-C protection was not used during any of the tests performed at the LRC mockup. However, heavy, bulky clothing was worn to protect personnel from the cold, and heavy welders' gloves were used by the operator. If an improved combination welder's mask can be obtained and anti-C gloves can be demonstrated to fit inside the welders' gloves, the added bulk of anti-C clothing should present no problems. A problem exists with small particles of molten metal being blown onto the prone operator at high enough temperatures to burn small holes in his clothing. The operator must be protected to avoid holes in airtight garments.

Tests in the mockup revealed the importance of the ground connection between the console and the work to be cut. Up to 400 amperes of current flows through a 4/0 lead during actual cutting. Therefore, it is important that the welding clamp connection to the work ensure a low-resistance, short-path connection.

The test connection was made to one of the angle iron members of the mockup, and no trouble was experienced during cutting. A poor ground connection was simulated by placing a piece of notebook paper between the frame member and the clamp while performing a cut. The cut was successful, but the paper was burned and a portion of the angle iron was melted. In service, this clamp will be attached to the standard CRDM removal tool, but the electrical path from the tool to the leadscrew has not been evaluated. If there is a high-resistance joint in the path, welding could occur while cutting. The actual electrical path should be evaluated during mockup training before actual operations.

5.3. In-Head Mockup - Plasma-Arc Mockup Design and Construction

In-head plasma-arc cutting was performed using the mockup (shown in Figure 5-10) at B&W's LRC. The simulation of the plenum cover and guide tube is contained in the wooden platform resting on the ground inside the standard construction scaffolding. The scaffolding was used to obtain the height of the working platform that simulated the working surface on top of the service structure. Included in the mockup was a sample leadscrew, the leadscrew support tube, the simulated guide tube, and simulation of an adjacent CRDM nozzle. The height of this platform was designed so that the height from the top of the standard nozzle to the top of the simulated control rod brazement (8-inch-diameter pipe) was the same as it would be in the reactor.

A vertical adjustment was provided so that the "gap" between the top of the control rod guide brazement and the bottom of the leadscrew support tube could be set anywhere within the 2.625 range permitted by tolerance stackup. Completion of the mockup consisted of assembling the 206-inch-ling MST to the nozzle flange with the top of the tube extending through the work platform. This provided a path (hole) identical to that at TMI-2. An added feature (not shown in Figure 5-10) consisted of a flexible cable attached to the top of the leadscrew cutting sample. The cable was connected, through a hole in the working platform, to a load cell with provisions for axially preloading

Figure 5-10. Mockup In-Head Cutting

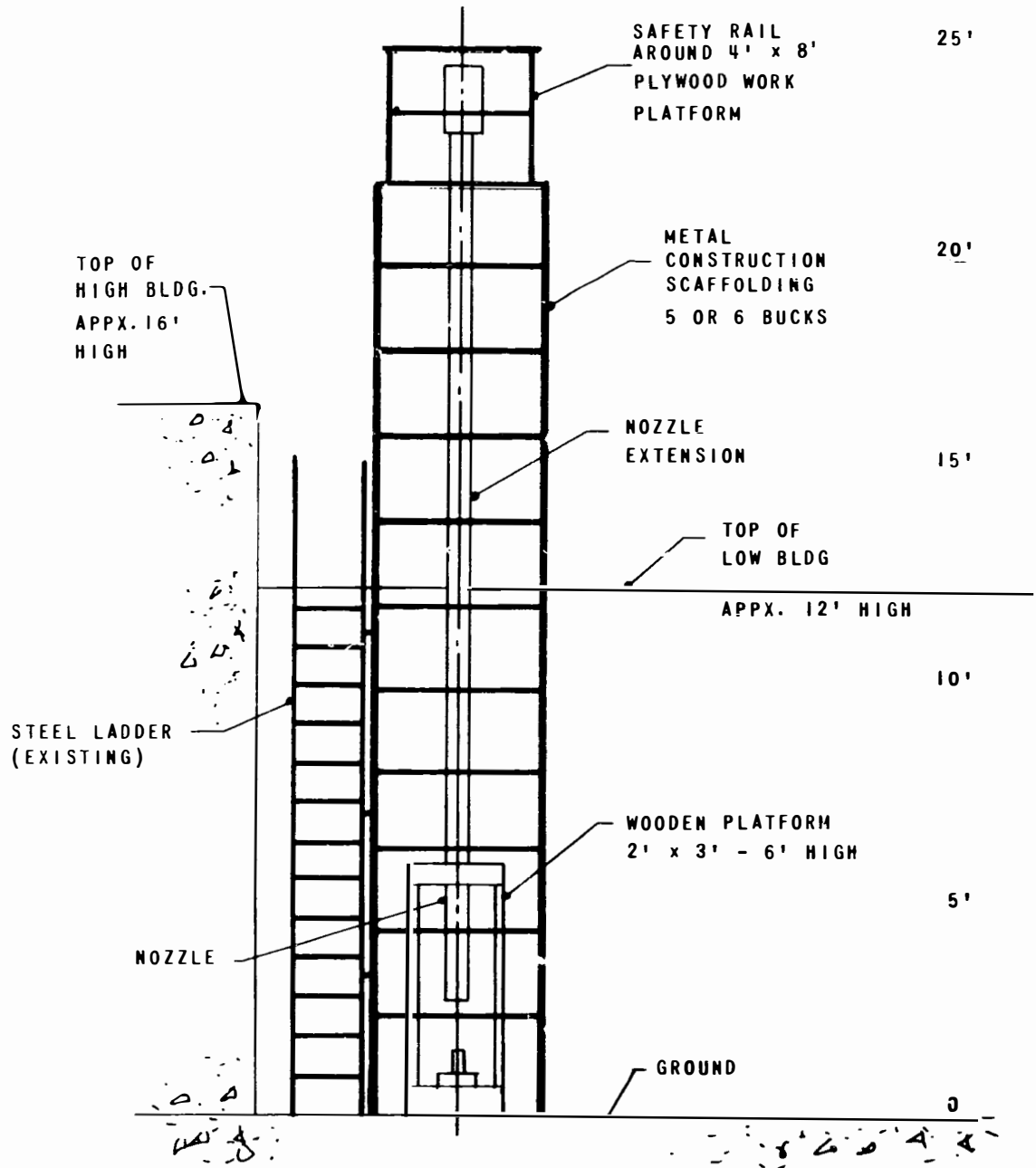

- NOTES: 1. LEVEL PLATFORM & SCAFFOLDING. TIE PLATFORM TO SCAFFOLDING & TIE SCAFFOLDING TO STEEL LADDER.
2. CUT HOLE IN PLYWOOD PLATFORM TO STABILIZE NOZZLE EXTENSION Laterally; WEIGHT SUPPORTED BY WOODEN PLATFORM.

the sample leadscrew. This simulates the preload imposed when using the standard CRDM removal tooling. It also provides a positive indication to the operator on the platform when the screw is cut, due to the sudden load change. A set screw arrangement at the bottom of the leadscrew sample permitted tension to be applied. Rotation of the leadscrew varied the leadscrew clamp elevation.

Problems During Testing

Both in-head manipulators have assembled lengths of approximately 25 feet and had to be designed in sections to meet defined TMI-2 building access requirements. This required that connectors be used for the various control cables at each joint and proved to be one of the most troublesome features of the design. The design concept required the tooling to work under the missile shield. This limited the vertical height above the working platform, and the manipulators had to be assembled in sections. The height limitation prevented the use of a crane, and succeeding sections of the manipulator had to be hand-held in the vertical position while connections were being made. This proved to be very difficult even though the connectors were designed to be a snap-on type. Space limitations also required that the connectors be small and misalignment of the sections caused damage. Substantial efforts were expended in trying to solve connector problems. The requirements were later changed to permit removal of the missile shield. This allowed for the use of a crane and assembly of the entire manipulator in a horizontal position on the floor of the building. The entire assembly can now be inserted into the MST by the crane and stored on the floor while not in use. The design of the original connectors was not suitable for horizontal assembly, so it was changed to a male-female threaded type. This required increased assembly time but was acceptable since it was to be a "one time" assembly.

A second problem that had to be corrected pertained to "looseness" of the joints in the manipulators, which prevented proper centering on the leadscrew to be clamped or cut. The centering links were designed to move the bottom end of the manipulator ± 0.375 inch, and looseness prevented proper operation. Joints were designed with a 2-inch overlap and a tight fit, but a few mils tolerance in a 2-inch joint was greatly magnified in the 4-foot length of the bottom section of the manipulator. A round eccentric collar was added around the lower joint of the clamp manipulator so that hand tightening eliminated

(all joint movement. The lower section was welded to the middle section of the plasma-arc cutting manipulator. These changes corrected the problems and permitted the centering links to move the bottom end of the manipulator ± 0.375 -inch radially relative to the leadscrew, as originally intended.

Tests revealed that expected "feel" was not adequate to define the exact point at which the clamp manipulator (bottom surface of the clamp) touched the top surface of the control rod brazement. The manipulator was lowered (with the capture nut) until its entire weight rested on the mechanical stops located on folding members of the lower arm assembly. This situation was corrected by the addition of a microswitch with an actuator operated from the bottom surface of the clamp. The switch operates a light at the top of the manipulator. Mockup tests showed that this system worked very well and eliminated excessive loads on the lower joints.

Capturing the leadscrew with the clamp requires a 90-degree rotation of the lower arm assembly (i.e., clamp top surface) with respect to the axis of the manipulator. It was found that the winch used to rotate the manipulator arm required a finer adjustment than that obtained from the pawl latch. An adjusting screw was added to the winch cable to permit calibration of cable length so that one of the pawl stops on the winch could be used to ensure exact 90-degree rotation. This stop was marked on the winch to ensure repeatability in future use. Permanent, adjustable, and pinned stops were tried, but space requirements set the stop bearing surfaces so close to the centerline of rotation that slight material deformation caused errors of 1 to 3 degrees. These stops proved adequate for the plasma-arc cutter manipulator since true 90-degree rotation was less critical for this tool.

A number of minor developmental problems were encountered during the test program and were corrected. Some of these are listed below.

1. The captive nut material was changed from aluminum to stainless steel to prevent thread galling.
2. A broken microswitch was replaced, and the mounting was changed to provide adjustment and prevent future excessive loading on the switch.
3. The clamp rotating link was stiffened to prevent deformation.
4. The clamp rotating pin was removed from the design and the procedure revised to reflect this change. This improved the rotating procedure by requiring rotation in one direction only to "bottom" the clamp on the brazement.

4. The clamp rotating pin was removed from the design and the procedure revised to reflect this change. This improved the rotating procedure by requiring rotation in one direction only to "bottom" the clamp on the braze-ment.
5. Crane lifting lugs were added to both manipulators.

Erratic performance of the PAK 44 plasma-arc equipment resulted in added effort and program delay. The problem involved the inability to obtain reliable pilot-arc operation. A high frequency pilot-arc occurs at the torch when an operating control is depressed at the hand-held torch position for hand cutting and/or at the remote operator position for in-head cutting. This arc ionizes the plasma gas flowing from the torch tip, permitting it to conduct current from this negative point to the positive-grounded work piece when the gap is reduced to a proper value. Conditions of intermittent to no pilot-arc were experienced; field servicing failed to correct the problem, and the equipment was returned to the distributor. The vendor consulted the manufacturer and replaced parts on the torch end, using parts from the spare part kit, and returned the equipment. A strong pilot-arc was achieved on all subsequent cuttings with both torches, but an intermittent condition occurred on several attempts. This was corrected by releasing the control and trying again, which is the procedure recommended by the manufacturer. We recommend cleaning the torch end and replacing tips per instructions in the equipment manual before entering the TMI-2 containment building.

Concern was raised about the possibility of having to cut molten material from the cut leadscrews that may be adhering to the adjacent leadscrew. Such material could prevent installation of a leadscrew clamp. This was checked in the mockup with a piece of leadscrew 12.14 inches away from the one cut. "Over-spray" was acceptable since only particles that did not prevent clamp installation occurred. Cutting underwater at this location, rather than planned air cutting, has been suggested, but available information indicates that cutting current must be doubled to achieve equivalent cutting. Therefore, no effort was made to evaluate underwater cutting. Air cutting required the maximum current available from the machine.

A demonstration of in-head cutting was held without problems after initial adjustments of two of the control cables. These had been incorrectly assembled in the clamp manipulator when the cable adjustment was added the

previous day. Both manipulators were hand-installed vertically in the MST since a crane was not available. This simulated crane installation. This demonstration followed the approved procedures on a step-by-step basis, and the leadscrew clamp was "captured" and rotated downward to the simulated brazement before removing the manipulator. The two-piece plasma-arc manipulator was then inserted into the manipulator tube. Ninety-degree rotation of the torch end was achieved, as well as proper spacing from the leadscrew. After a ground connection was made to the extended upper end of the leadscrew sample, the console was activated and the operator cut the leadscrew in one pass using the "remote" pilot-arc control. The cut was made by rotating the torch past the leadscrew as the entire manipulator was rotated at the top of the working platform. This technique involves rotating the torch head well past the leadscrew centerline, starting the pilot arc, and slowly sweeping past the leadscrew. A mark at the top of the manipulator was set on a gage to indicate the leadscrew centerline at the point of "capture" to aid in the cutting operation. However, "feel" in the manipulator is not sensitive enough to ensure a complete cut on the first try, and additional sweeps can be made until cutting is complete. Section 5.2 includes comments on proper grounding at TMI-2 since grounding for in-head cutting will be identical.

5.4. Push-Pull Tool Mockup

5.4.1. Mockup Design and Construction

Mockup testing of the push-pull tool was performed in the machine shop at LRC. The platform located at the second floor level in an LRC building overlooking the shop floor was the correct height to serve as a working platform for testing. The test setup is shown in Figure 5-11, and dimensions locating the tool flange with respect to the "window" accurately simulate the field dimension are shown in Figures 5-6 and 5-7. Before actual testing was started, it was realized that installing the hydraulic jack would be difficult because of the permanent iron protective railing around the platform. Therefore, a wooden platform, approximately 1 foot high, was placed on the existing platform and the equipment was moved up. The jack was installed over the top of the railing while standing on the wooden platform and working through the "window." The entire tool was raised by the same amount using a metal platform, equal in height to the wooden platform, on the shop floor. This mockup shows the condition following completion of ex-head cutting. In this condition, cutting

Figure 5-11. Push-Pull Mockup at LRC
(B&W Lynchburg)

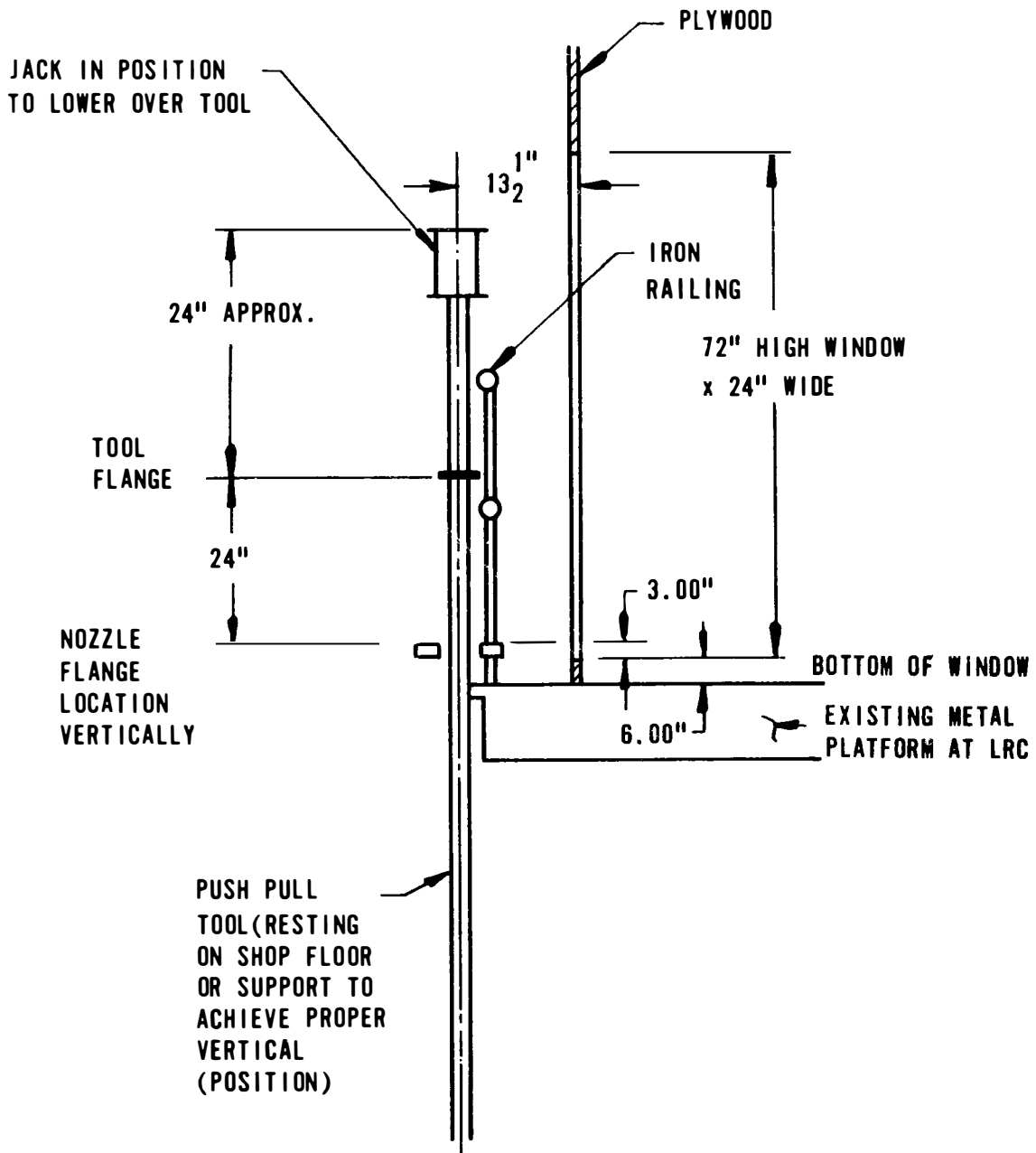

has been completed, the CRDM and leadscrew support tube have been removed, the push-pull tool has been lowered into the nozzle over the leadscrew, and the centering and lowering tool has been removed.

5.4.2. Mockup Testing

Initial tests were conducted without the window and wooden platform. These features were added after initial testing to ensure that the jack could be installed under field conditions. Changes were also made to hardware, the method of applying restraining cables, and the jack mounting method to reduce cycle time. During early testing, the tool flange was secured to the iron railing with flexible metal cable. This caused minor deformation to the railing when the tool sheared the leadscrew pins, causing a sudden release of stored energy. This method of restraint was changed and the restraining cables were fastened to I-beams under the metal platform that could easily absorb the released energy.

Demonstration tests were conducted and the pins holding the leadscrew to the flanged test piece were sheared as required. Pins selected for tests were of the same material and size as those at TMI-2. These pins were fully hardened to a value equal to or greater than those expected in the field.

Testing began by lowering the top section of the tool over the leadscrew inside the bottom section. Then the spreader bar was pushed down to collapse the tool "split nut," and the sleeve was inserted around the outside diameter of the top section to hold the "split nut" firmly on the leadscrew. The hydraulic jack was then lowered over the tool until it rested on the tool flange, where it was bolted. A hardened pin was inserted through a hole in the top section member clamped to the leadscrew. Action of the jack pressing upward on this pin and downward on the flange produced the force to shear the pin. Before applying hydraulic pressure a hand pump was used to secure the top section of the tool to the tool flange with a flexible steel cable to prevent a "missile effect" when the pin was sheared.

5.5. Bolt Removal Tool Testing

Testing of the bolt removal tool at DPSC resulted in several design improvements.

1. Additional gussets were added to increase the strength of the two sleeves on the tool plate.

2. Lifting lugs were enclosed to eliminate the possibility of dropping the tool.
3. The torque multiplier assembly was joined together by lanyards to reduce loose parts.
4. The torque multiplier bearing was connected to the tool plate by a lanyard.
5. The torque holder has been shortened to clear adjacent CRDMs protruding from the service structure.
6. All parts that have potential to rust have been painted.

5.6. Purge System Mockup

Equipment selected for the purge system was connected together in the SPIS shop using flexible round pipe cut to the proper length for use at TMI (arrangement shown in Figure 5-12). A wooden plenum chamber (approximately 18 × 24 × 36 inches) was made with three openings approximately 3.0625-inch in diameter to simulate the three MSTs (CRDMs) and four openings that permitted attachment of the four 1.5-inch lines from the manifold. Flanges at the end of these lines will be connected to thermocouple nozzle flanges at TMI-2. Equivalent orifice diameters were calculated for the CRDMs as well as for the thermocouples. Metal plates with 0.5-inch-diameter holes were inserted between the thermocouple flanges and the box to simulate the thermocouples, while the 3.0625-inch diameter holes in the plywood box simulated the MSTs. Small openings were also made in the box to insert a rubber tube connection to the controller and to provide a top for the manometer used to read the plenum vacuum. Vacuum gages were provided to measure pump suction and vacuum on the pump side of the thermocouple flange as shown in Figure 5-12.

Tests were conducted and data taken over a range of conditions where the CRDM orifices were progressively closed off from "all three open" to "all three closed." Vacuum readings were recorded and air flow was calculated for all parts using the pressure drop across the 0.50-inch-diameter orifice. These data proved that the system met the 0.1-inch H₂O vacuum requirements in the plenum at the design flow rate. Controlled settings required to start opening the vacuum breaker were recorded for each point and found to be consistent. All tests were run for each pump; minor differences were well within the pump manufacturers' specifications. Test results proved that flow rate decreased very little until two and one half CRDM orifices had been closed off. A review of the data showed that the pressure drop across the thermocouple flange orifice was much greater than the drop across the CRDM orifice.

Figure 5-12. Purge System Mockup at B&W Special Products

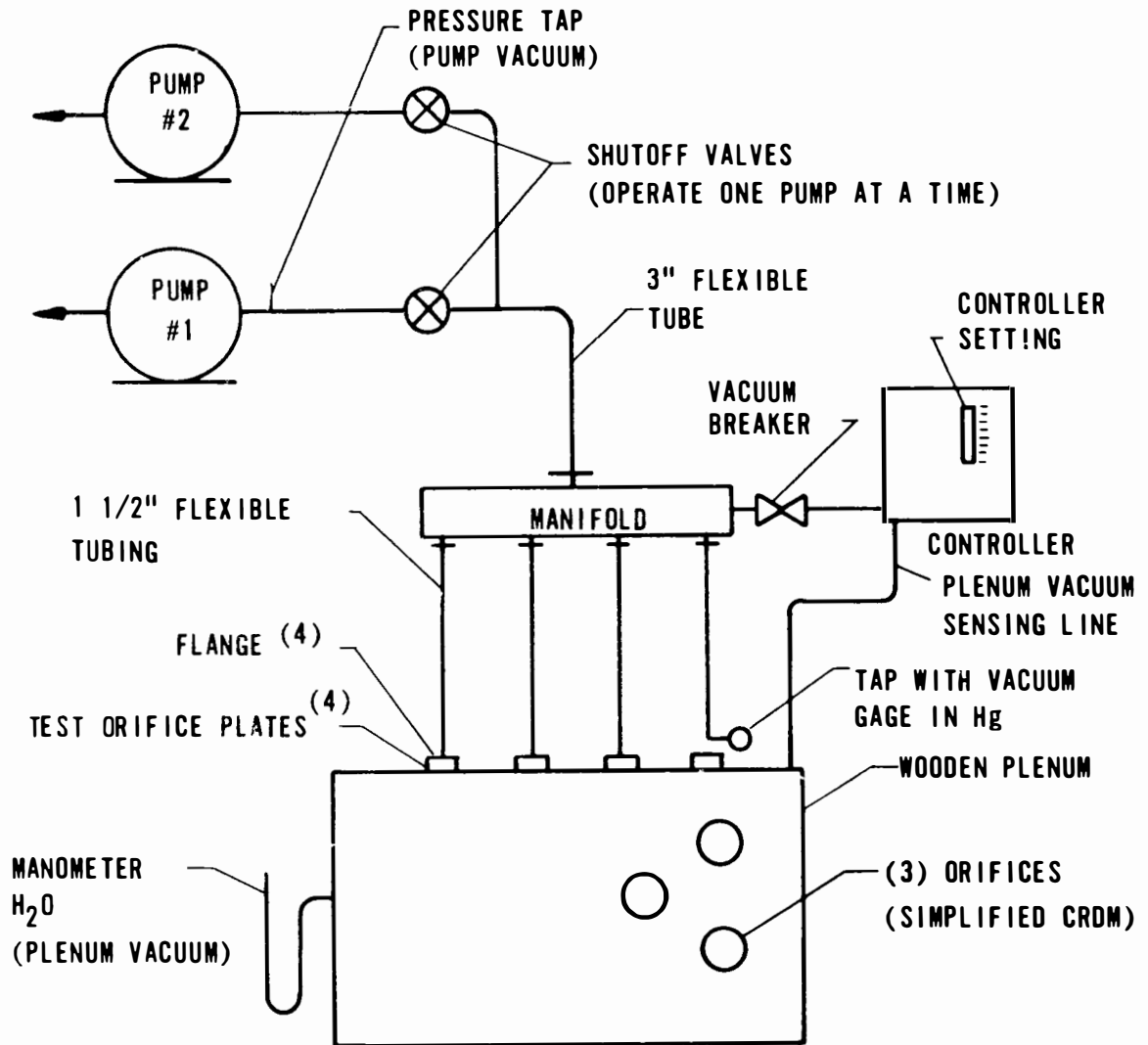

NOTES: 1. VACUUM BREAKER OPENS & CLOSSES DEPENDING ON CONTROLLER SETTING & PLENUM VACUUM.

The flow resistance due to the long, small-diameter thermocouple pipe controls flow until the CRDM openings are virtually closed off. This also means that these openings must be sealed off during plasma cutting to ensure that pressure buildup does not cause outflow of contaminated gas and/or air.

5.7. Water Level Sensing System Mockup

The water level sensing system mockup is shown in Figure 5-13. It consisted of mounting a vertical panel containing the equipment from the Special Products shop and making the two hose connections shown in the figure. A regulated nitrogen source was used to provide flow and source pressure to the system. A water-filled, 4-inch diameter, 6-foot piece of plastic pipe with one end sealed provided a means to check water level. A piece of small-diameter rigid plastic tubing was taped to a 5-foot-long yardstick in lieu of the actual bubble pipe. Raising and lowering this assembly provided a simple means of varying the water level with respect to the "0" end (bubble end) of the pipe. An ammeter was connected to the output terminals of the transmitter after a 600-ohm load resistor was connected across the terminals as required by the transmitter manufacturer.

Tests were conducted to verify that actual set water levels were indicated on the water level gage within ± 5 inches of actual; transmitter output was recorded for each setting. Both gage readings and transmitter outputs were linear when plotted against set levels, and the calibration curve of milliamperes versus level provides for monitoring water level remotely in the field. Both alarms were set to alarm at high and low points. These were checked by moving the yardstick to these levels, and both alarms worked properly. System response time was checked by moving the yardstick to simulate a 20-inch change in the level within 5 seconds. The new level was correctly indicated within less than 10 seconds, fully meeting requirements. All these tests were completed and documented. No problems required "fixes" during the mock-up test.

5.8. Manipulator Support Tubes

After demonstrations, the MSTs were improved by lowering the bail supports. This eliminated interference with a plate on the bolt tool. Also, the closure plugs, which seal the support tubes when not in use, were modified.

Figure 5-13. Water Level Mockup at B&W Special Products

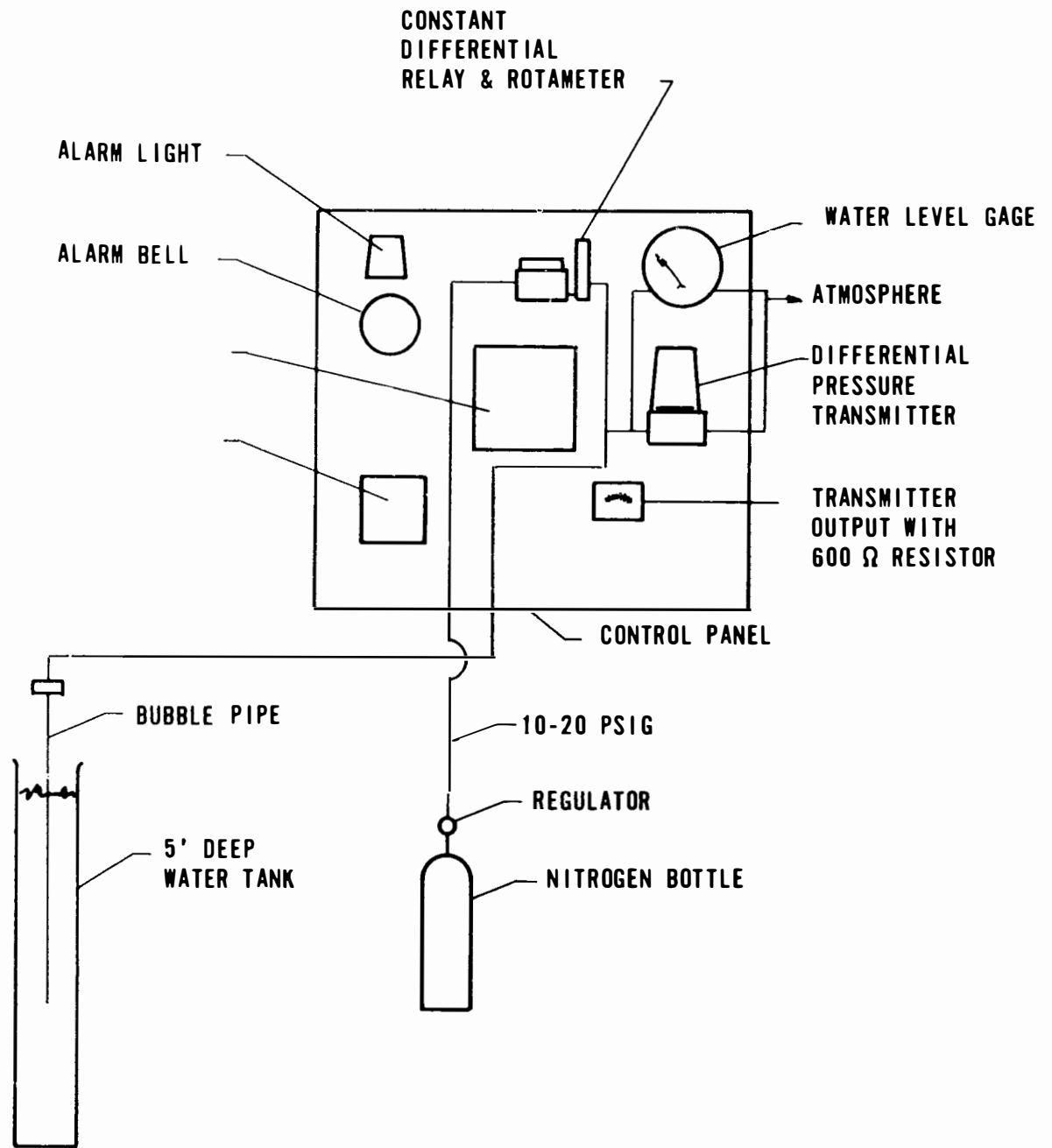

5.9. Underwater Lights

Tests performed on the underwater lights revealed the need for additional drainage holes to be drilled in the Plexiglass cover adjacent to the base of the bulb. This permitted the entire quantity of air to escape from inside the Plexiglass enclosure, thereby allowing water to totally surround the bulb and give the proper heat conduction.

The in-head lights, used to illuminate the upper head area for inspection by camera, required no design changes other than the elimination of the factory-supplied glass protective cover to increase the heat conduction from the bulb. The variacs, which control the light intensity of the underwater and in-head lights, were equipped with limit switches to prevent overpowering the bulbs.

5.10. Stator Removal Tool

Design changes on the stator removal tool include the replacement of set screws on the intermediate plate. These screws were used to serve the upper section of the stator. T-handled cable clamps are now used to help speed up operations. The contact area between the cable clamps and the cable has been modified to reduce cable deformation. However, the intermediate plate is no longer required in the adopted procedure. A triple-leg chain for lifting the tool was also developed to facilitate operations.

5.11. Camera and Light Manipulators

Tests on the camera and light manipulators resulted in several modifications. A positive middle coupling was added to eliminate the twisting of cables inside the manipulators at assembly. The factory-supplied winch handle proved unsatisfactory due to awkward operation; it was replaced by a large wheel with an adapter for a twist drill. The adapter expedited the winding of excess manipulator pull cable on and off the winch. Indexing marks were placed on the manipulators and manipulator pull cables to eliminate uncertain geometric positioning. Dedicating the two manipulators to a particular task proved useful. One manipulator is now used only for the murky water viewing apparatus, while the other is used for all remaining inspection purposes with the camera and auxiliary lighting. Stainless steel bushings were added to eliminate excessive wear by the manipulator pull cable on the upper ID of the manipulator.

5.12. Mockup Testing of Murky Water Viewing Attachment

Mockup testing of the murky water viewing attachment resulted in a redesign of component parts. The viewing bag was redesigned because previous designs leaked.

The tube has been lengthened so the attachment will clear the brazement instead of dropping inside, as discovered from testing. Hose lines and camera cable have been taped together and heat shrink tubing has been added over the headers to decrease the chances of entwining the conglomerate of hoses and cables inside the manipulator. The camera cable-hose bundle has been marked for vertical positioning to facilitate lowering and raising the camera about the plenum cover and cylinder. This reduced the chances of getting the camera stuck inside the reactor. A water reservoir has also been added for deploying the bag.

5.13. Blind Flange Tool

After testing, the blind flange tool was modified to be used with the missile shields in place.

5.14. Missile Shield Discussion

All the tools are capable of working under the missile shields located above the service structure. This includes the following:

- Ex-head leadscrew cutting tool.
- CRDM blind flange replacement tool.
- Manipulators.
- Bolt removal tool.
- Swipe tool.
- Stator lifting tool.
- Manipulator support tube.
- Push-pull leadscrew separator tool.

These tools are either broken into sections or are short enough to fit below the missile shield and be inserted through the service structure.

5.15. Rigging Information

All interface connections of the tools to the crane hook will be made via bails connected to the tools. Most of the lifting will be done with the polar

crane, provided the missile shields are removed. An electric hoist will be connected in series with the polar crane if finer adjustment is required. If the missile shields cannot be removed, an auxiliary crane will have to be supplied under the missile shields.

5.16. Tool Access Through Air-Lock

All tools, with the exception of the ex-head cutting tool, have been designed to either break in sections or fold to a length of 12 feet or less to facilitate their passage through the personnel hatch. Tools 12 to 14 feet long, such as the ex-head cutting tool, will pass through the personnel hatch but require special attention in positioning.

6. FUTURE WORK

The work performed within the scope described in this report concluded with the development of tools and equipment for viewing the interior of the TMI-2 reactor plenum assembly and the top of several fuel assemblies. These tools were demonstrated on simplified mockup assemblies with procedures for tool operations and handling. In order to fulfill the intent of the overall program; i.e., obtain pictures inside the TMI-2 reactor vessel, more work will be required. The following sections provide a brief discussion of some of the aspects of this work.

6.1. ALARA Concerns

The development of tools and procedures concentrated primarily on proof of design, i.e., establishing that the tools were capable of performing the tasks mechanically and optically. Each task must be examined to better understand the possible and/or probable consequences of its use in the contaminated environment of TMI-2. While radiation considerations were considered in the design and use of the tools and equipment, their use should be examined more rigorously. More surveys of the area on top of the control rod service structure and near the top of the RV head could reveal areas of lower radiation activity that could influence where and how the in-head inspection will be performed. Detailed analysis of every part of the inspection program that involves entry into the RV should be examined to determine such things as the following:

- Total man-rem exposure expected.
- The time each instrument will be in the vessel.
- Expected radiation streaming up the manipulator tube.
- Expected contamination carried by the instrument upon withdrawal.
- Modifications that might be made to the tools or procedures that would decrease exposure or performance time.
- Needs for shielding and/or area decontamination.

6.2. Implementation Phase

The final phase of the in-head inspection program will have to consider closely the impact of the work at TMI-2. A workscope for such a phase would have to include

- Safety evaluations (criticality monitoring, criticality safety).
- Accident analysis and TRR preparations.
- Venting of reactor coolant system (RCS).
- Methods of depressurizing the RCS.
- RCS water level monitoring and methods for lowering.
- Needs for decontaminating the RCS.
- Boron control.
- Rigging and handling needs.
- Operator training.
- Steam generator conditioning.
- Installation of support systems, work platforms, and equipment access.
- Detailed procedure development.
- Assembly of CRDM uncoupling tools.
- Support systems required – electrical, service air, and flushing for tools.

6.3. Plant Conditions

At present, the TMI-2 RCS is at approximately 100 psi and 90F. It is essentially full of water, i.e., a gas bubble probably exists in the system, but its size and location are speculative. When the in-head inspection is performed, the RCS will have to be at atmospheric pressure, vented, with a water level stabilized at approximately 1 foot above the plenum cover. In order to do this, a means to determine the level of the RCS water as it is lowered to the plenum cover will have to be developed. Suggestions have included a Heiss gage or sensitive electronic pressure indicators at either the decay heat drop line or the makeup sampling location. Both these locations are outside the reactor building and properly valved but are subject to the static pressure of the coolant in the RCS.

The top of each hot leg RCS pipe and each CRDM must be vented. This could be done by providing flexible tubing from the vent valves to the reactor building ventilation system, where it would eventually be exhausted from the building.

Venting the top of the pressurizer may also be considered. The RCS pressure is controlled by the standby pressure control system (SPCS). Decreasing the overpressure in the supply tank, will cause the RCS pressure to gradually decrease. The procedures for venting, lowering the level, and decreasing pressure will have to be examined to determine the sequence of these actions. If the volume of gas in the RCS is large, then significant expansion will occur as the pressure is lowered. This will require removal of a large volume of water from the system, perhaps more than should be removed. It might be better to vent and drain simultaneously.

6.4. Staffing and Training

The tooling developed for this program was demonstrated on a few simplified mockups; the demonstrations were conducted by the engineers who designed the tools. Radiation exposure did not inhibit the time spent in developing techniques and practicing them on these small mockups. This will not be the case on TMI-2 since the program cannot be accomplished in a few hours inside the reactor building. A series of reactor building entries will have to take place before all preparations are made and before the program is concluded. This task will require several teams of personnel, who must all be trained. The training requirement could best be fulfilled if a large, full-scale mockup of the control rod drive structure, RV head and the internals were available; such a mockup has been contemplated but not yet constructed. If such a mockup is not constructed in time to be used for this program, substitutes must be made available. These mockups could be provided by modifying those originally used to demonstrate the mechanical capability of the tooling.